



TM7000

TymMachine Time Code Generator/Translator

Revision C

User's Guide

8500-0101

February, 2004

TM7000
TymMachine TCG/T

TABLE OF CONTENTS

SECTION	PAGE
CHAPTER ONE	
GENERAL DESCRIPTION	
1.0	INTRODUCTION 1-1
1.1	USER'S GUIDE SUMMARY 1-1
A	CHAPTER ONE – GENERAL INFORMATION..... 1-1
B	CHAPTER TWO – INSTALLATION 1-1
C	CHAPTER THREE – OPERATION..... 1-1
D	CHAPTER FOUR – THEORY OF OPERATION..... 1-1
E	CHAPTER FIVE – MAINTENANCE, TROUBLESHOOTING, AND ADJUSTMENTS 1-1
F	APPENDIX A 1-2
1.2	PURPOSE OF EQUIPMENT 1-2
1.3	PHYSICAL DESCRIPTION 1-2
1.4	SPECIFICATIONS..... 1-4
1.4.1	INPUTS..... 1-4
A	AC POWER (POWER ENTRY MODULE J1) 1-4
B	RS-232 INPUT/OUTPUT (9 PIN D CONNECTOR J2)..... 1-5
C	HIGH STABILITY EXT. TIME BASE INPUT (BNC J5)..... 1-5
D	PULSE/1PPS INPUT (BNC J6) 1-6
E	CODE INPUT (BNC J8) 1-6
1.4.2	OUTPUTS..... 1-7
A	MISCELLANEOUS OUTPUTS (15 PIN D CONNECTOR J3) 1-7
B	MULTICODE DC CODE OUTPUT (BNC J4) 1-7
C	10MHZ SINE WAVE OUTPUT (BNC J5) 1-8
D	AGC OUTPUT (BNC J7) 1-8
E	RS-232 TIME WORD OUTPUT (9 PIN D CONNECTOR J9)..... 1-8
F	IRIG B AC CODE OUTPUT (BNC J10) 1-9
G	IRIG B DC CODE OUTPUT (BNC J11)..... 1-9
H	MULTICODE AC CODE OUTPUT (BNC J12) 1-10

TABLE OF CONTENTS

1.4.3	INTERNAL TIME BASE	1-10
	A. VCXO	1-10
	B. LOW NOISE OVEN OSCILLATOR.....	1-11
1.4.4	ENVIRONMENT	1-12
1.4.5	SIZE AND CONFIGURATION.....	1-12
1.5	SAFETY PRECAUTIONS AND HEALTH HAZARDS	1-13

CHAPTER TWO INSTALLATION

2.0	INTRODUCTION	2-1
2.1	INSTALLATION PROCEDURE.....	2-1
2.2	PRE-INSTALLATION CHANGES (IF DESIRED).....	2-1
	2.2.1 POWER SUPPLY.....	2-1
	2.2.2 STCG ASSEMBLY.....	2-1
	A. REAR PANEL BNC J5 CONFIGURATION	2-1
	B. REAR PANEL BNC J4 AND J12 CONFIGURATION	2-3
	C. REAR PANEL J9 9 PIN D CONNECTOR CONFIGURATION	2-3
2.3	RACK MOUNTING PROCEDURE	2-3
	2.3.1 TMRA.....	2-4
	2.3.2 ELEVATED OPERATING AMBIENT TEMPERATURE.....	2-4
	2.3.3 REDUCED AIR FLOW.....	2-4
	2.3.4 MECHANICAL LOADING.....	2-4
	2.3.5 CIRCUIT OVERLOADING	2-4
	2.3.6 RELIABLE EARTHING.....	2-4
2.4	CONNECTIONS	2-5
2.5	OPTION CARD INSTALLATION PROCEDURE.....	2-6

CHAPTER THREE OPERATION

3.0	INTRODUCTION	3-1
3.1	CONTROLS AND INDICATORS.....	3-1
3.2	CONTROLS	3-1
	3.2.1 POWER SWITCH	3-1
	3.2.2 NEXT SWITCH.....	3-2
	3.2.3 PREV SWITCH.....	3-2
	3.2.4 SELECT SWITCHS	3-2
	3.2.5 INTERNAL JUMPERS (LOCATED ON ASS'Y 100007)	3-2
	A. J21 RS-232 TALKER OUTPUT SELECT.....	3-2
	B. J20 MULTI-ENCODER OUTPUT SELECT.....	3-3
	C. J22 REAR PANEL BNC J5 CONFIGURATION.....	3-3

TABLE OF CONTENTS

3.3 INDICATORS 3-3
 3.3.1 LCD DISPLAY 3-3
 3.3.2 LED DISPLAY 3-3
 3.4 OPERATING PROCEDURES 3-4
 3.5 POWER ON/OFF 3-4
 3.6 INITIAL MENU SELECTIONS 3-5
 3.6.1 CHANGE DISPLAY FORWARD OR BACKWARD 3-5
 3.6.2 EXPLANATION OF SWITCH 3-6
 3.6.3 INTRODUCTION TO SELECT SWITCHES 3-6
 3.6.4 VERSATILE DISPLAY FUNCTION MENU 3-6
 3.7 GENERATOR OPERATION 3-7
 3.7.1 GENERATOR OPERATE MENU 3-7
 3.7.2 ADVANCE/RETARD OPERATION 3-8
 3.7.3 SYNC GEN OPERATION 3-9
 3.7.4 SYNC & VERIFY OPERATION 3-10
 3.7.5 1PPS TRACKING OPERATION 3-10
 3.7.6 GENERATOR SET-UP 3-11
 3.7.7 GENERATOR SET-UP INPUTS 3-12
 3.7.8 INPUTTING TIME 3-12
 3.7.9 INPUTTING PROPAGATION DELAY 3-13
 3.7.10 SETTING CONTROL FUNCTIONS 3-13
 3.7.11 EXTERNAL START PROCEDURE AND SET-UP 3-14
 3.7.12 SETTING GENERATOR OUTPUTS 3-15
 3.7.13 SELECTING ID (OR DAYS) 3-16
 3.7.14 SELECTING LS (LEAP SECONDS) 3-16
 3.7.15 SELECTING GENERATOR SPEED-UP (MULTI-CODE ENCODER) 3-16
 3.7.16 SELECTING GENERATOR RE/GEN (MULTI-CODE ENCODER) 3-17
 3.7.17 RS-232 I/O OPERATION/CONFIGURATION 3-18
 3.8 TRANSLATOR OPERATION 3-20
 3.8.1 TRANSLATOR CODE INPUT SELECTION 3-21
 3.8.2 TRANSLATOR IRIG CODE INPUT SELECTION 3-21
 3.8.3 TRANSLATOR NASA CODE INPUT SELECTION 3-22
 3.8.4 TRANSLATOR XR3/2137 CODE INPUT SELECTION 3-23
 3.8.5 TRANSLATING MENU 3-23
 3.8.6 FILTERS 3-24
 3.9 EXTERNAL FREQUENCY INPUT OPERATION 3-26
 3.10 10MHZ SINE WAVE OUTPUT 3-26
 3.11 RS-232 INPUT/OUTPUT (I/O) 3-27
 3.11.1 INTRODUCTION 3-27
 A. PACKED BCD FORMAT 3-28
 B. ASCII FORMAT 3-28
 3.11.2 PROGRAMMING 3-28
 3.11.3 TO ENTER SETUP AND CONTROL DATA 3-28
 3.11.4 TO REQUEST OUTPUT OF TIME AND STATUS MESSAGES 3-29

TABLE OF CONTENTS

3.11.5	PROGRAMMING THE GENERATOR	3-30	
	A. SELECT/DISPLAY DATA MODE	3-30	
	B. SLOW CODE FRAME PERIOD SELECTION	3-30	
	C. SET TIME CODE GENERATOR TIME	3-30	
	D. SET PROPAGATION DELAY COMPENSATION	3-30	
	E. SELECT MULTICODE OUTPUT(S).....	3-31	
3.11.6	PROGRAMMING THE TRANSLATOR	3-31	
	A. TAPE PLAYBACK SPEED RATIO.....	3-31	
	B. TRANSLATOR FUNCTION CONTROLS	3-32	
3.11.7	PROGRAMMING THE TAPE SEARCH CONTROL OPTION	3-32	
	A. TAPE SEARCH TIME VALUES	3-33	
	B. SELECT PROGRAMMED TAPE SEARCH INTERVAL.....	3-33	
	C. SELECT TAPE TRANSPORT DELAY	3-33	
	D. EARLY CLOSURE DELAY SELECTION.....	3-33	
	E. TAPE SPEED SELECTION.....	3-34	
	F. AUTOMATIC TAPE SEARCH MODE CONTROL	3-34	
	G. MANUAL SEARCH TAPE MOTION CONTROL	3-34	
	H. TRANSPORT CONTROL PARAMETERS	3-35	
3.11.8	PROGRAMMING TIME OUTPUT REQUESTS	3-35	
	A. TIME OUTPUT REQUEST	3-35	
3.11.9	PROGRAMMING STATUS OUTPUT REQUESTS	3-35	
	A. GENERATOR TIME VALUES	3-36	
	B. PROPAGATION DELAY COMPENSATION.....	3-36	
	C. REQUEST MULTICODE STATUS	3-36	
	D. TRANSLATOR TIME VALUES.....	3-36	
	E. TRANSLATOR CONTROL SETTINGS	3-37	
	F. TAPE SEARCH START/STOP TIME VALUES.....	3-38	
	G. TAPE TRANSPORT CONTROLS	3-38	
	H. TAPE SEARCH STATUS.....	3-39	
3.11.10	TIME WORD OUTPUT FORMATS (RS-232 I/O).....	3-40	
3.12	RS-232 TIME WORD OUTPUT (TALKER)	3-42	
	3.12.1 INTRODUCTION	3-42	
	3.12.2 GENERAL DESCRIPTION	3-42	
	3.12.3 TERMINAL TYPE	3-42	
	3.12.4 DCE HANDSHAKING	3-42	
	3.12.5 MODES OF OPERATION	3-43	
		A. SYNCHRONOUS MODE	3-43
		B. ASYNCHRONOUS MODE	3-44
	3.12.6 MESSAGE FORMAT	3-45	
		A. ASCII/BCD FORMAT	3-45
		B. BAUD RATE.....	3-46
		C. STOP BIT	3-46
		D. PARITY	3-46

TABLE OF CONTENTS

E. WORD LENGTH	3-46
F. PREAMBLE	3-47
G. POSTAMBLE.....	3-47
H. QUALITY INDICATOR.....	3-48
I. DATA FORMAT.....	3-48
J. LOSS AND ERROR DATA.....	3-49
3.12.7 OPERATION.....	3-49
3.12.8 TIME WORD OUTPUT FORMATS (RS-232 TALKER.....	3-49

CHAPTER FOUR THEORY OF OPERATION

4.0 LOGIC DESCRIPTION AND USE	4-1
4.1 GENERAL.....	4-1
4.2 DETAILED LOGIC DESCRIPTION.....	4-5
4.3 [5] STCG (I/O AND DAC).....	4-7
4.4 [4] STCG (PROP DELAY)	4-7
4.5 [6] STCG (GENERATOR CODE).....	4-7
4.6 [2] STCG (GENERATOR μ P.....	4-8
4.7 [3] STCG (GENERATOR VIAs	4-9
4.8 [7] TRANSLATOR AGC).....	4-11
4.9 [8] STCG (TRANSLATOR μ P)	4-12
4.10 [9] TRANSLATOR FILTS)	4-14
4.11 [10] RS-232 TALKER	4-14
4.12 [12] RS-232 I/O	4-14
4.13 [13] MULTI-ENCODER	4-15
4.14 [14] MULTI-ENCODER (PLL)	4-15
4.15 DISTRIBUTION BOARD (100008).....	4-15
4.16 DISPLAY ASSEMBLY (100009).....	4-15

CHAPTER FIVE OPERATION MAINTENANCE AND ADJUSTMENTS

5.0 INTRODUCTION	5-1
5.1 TOOLS AND TEST EQUIPMENT REQUIRED	5-1
5.2 PREVENTATIVE MAINTENANCE	5-2
5.3 TROUBLE SHOOTING.....	5-3
5.3.1 POWER-UP SELF TEST	5-3
5.3.2 GENERATOR (part of STCG).....	5-4
5.3.3 TRANSLATOR (part of STCG).....	5-4
5.3.4 SYSTEM TROUBLES	5-5
5.3.5 MANUAL SYSTEM RESET	5-7
5.4 REPLACING AN OPTION MODULE.....	5-7

TABLE OF CONTENTS

5.5	Adjustments and Test.....	5-8
5.5.1	OSCILLATOR ADJUSTMENT	5-9
	A. STANDARD TCXO OSCILLATOR ADJUSTMENT	5-9
	B. OPTIONAL OVEN OSCILLATOR ADJUSTMENT	5-9
5.5.2	FREQUENCY OUTPUT AMPLITUDE ADJUSTMENT.....	5-10
5.5.3	CODE OUTPUT ADJUSTMENT.....	5-10
5.5.4	LCD CONTRAST ADJUSTMENT	5-10
5.5.5	LOS THRESHOLD ADJUSTMENT	5-11
5.5.6	MULTI-ENCODER CODE OUTPUT ADJUSTMENTS.....	5-11
5.5.7	PLL (CARRIER FILTER) ADJUSTMENTS	5-12
5.5.8	PLL (CARRIER FILTER) TESTS	5-13
5.6	FIRMWARE/SOFTWARE UPGRADING.....	5-14

APPENDIX A OPTION DESCRIPTIONS

TM Opt 02A	Tape Search with AUX (DIP Relays).....	A-1
TM Opt 04B	Fast Parallel Outputs (BCD).....	A-11
TM Opt 07A	RS-232 Interface	A-14
TM Opt 14	Serial Encoder.....	A-28
TM Opt 15	Multi-Code Serial Encoder	A-30
TM Opt 17	Read DC Code	A-34
TM Opt 18	Slow Code.....	A-41
TM Opt 27	Video Time Inserter	A-44
TM Opt 32	Distribution Module, 600 Ω Driver	A-51
TM Opt 39	Distribution Module, 50 Ω Driver	A-53
TM Opt 45	Buffer/Pulse Rate Module	A-56

CHAPTER ONE

GENERAL DESCRIPTION

1.0 INTRODUCTION

This User's Guide contains procedures and descriptive information for proper installation and operation of the TM7000 TymMachine Time Code Generator/Translator (TCG/T).

The TymMachine has many options designed to meet individual instrumentation requirements. This manual describes all configurations of the basic TymMachine instrument and comes with complete specifications. Descriptions of PLUG-IN options may be found in Appendix A.

1.1 USER'S GUIDE SUMMARY

This User's Guide is divided into the following chapters:

- A. CHAPTER ONE - GENERAL INFORMATION**
This chapter includes a general description of the TM7000 and provides technical specifications.
- B. CHAPTER TWO - INSTALLATION**
Describes initial inspection, preparation for use, and installation.
- C. CHAPTER THREE - OPERATION**
Describes both local and remote (RS-232 I/O) operation of the unit.
- D. CHAPTER FOUR – THEORY OF OPERATION**
Provides information on logic description and theory of operation.
- E. CHAPTER FIVE – MAINTENANCE, TROUBLESHOOTING, AND ADJUSTMENTS**
Provides a guide to the maintenance and troubleshooting of this instrument. A description of the available adjustments is also provided.
- F. APPENDIX A**
The Option Descriptions for all standard options are provided in this Appendix.

CHAPTER ONE

1.2 PURPOSE OF EQUIPMENT

The TymMachine performs two basic functions. First, it operates as a Time Code Generator using an internal 10MHz oscillator, or optionally using an external frequency input (1-10MHz) as its time base. If the SYNC-GEN feature is utilized, the unit can function as a Synchronized Time Code Generator, synchronizing the generated outputs to an input code. Secondly, it operates as a Translator using an input Serial Time Code as a time base. With the addition of a double-wide option assembly, the TCG/T is also usable as a Tape Search System.

When used as a Generator, the 10MHz oscillator is divided down to 1PPS. This divider is called the minor time counter. The 1PPS is further divided and the count permuted so as to generate BCD Time-of-Year in seconds, minutes, hours, and days. This divider is called the major time counter. The terms from the major time counter are decoded into decimal form and used to drive a LED Display. The initial time count must be manually preset into the instrument. The Generator operation is continuous even during operation of the Translator. See Chapter Four, Theory of Operation, in this User's Guide for a more detailed description of the Generator.

The TymMachine Translator relies upon an input Serial Time Code for its time base. This code is typically a member of the IRIG family. The carrier frequency of the time code is used for the clock and the time information is automatically set into the major time counter of the Translator. Chapter Four, Theory of Operation, in this User's Guide gives a more detailed description of the Translator.

The terms derived from both the major and minor time counters of the Generator and Translator are also used to drive option circuits which develop Serial Time Codes, Parallel Outputs, and Pulse Trains, etc.

In addition to the basic IRIG B generator, the TM7000 contains a Multi-Encoder to generate additional time codes, an RS-232 I/O, and an RS-232 Talker.

1.3 PHYSICAL DESCRIPTION

The TymMachine is constructed in a 1¾ inch package requiring a minimum 19 inch rack mounting space. A decimal (LED) display, located on the front panel, shows either generated time or translated time, depending on the mode of operation. The LCD Display along with the switches are used to set-up and control the TCG/T. All operating controls, with the exception of the POWER switch, are located on the front panel. The basic and optional plug-in assemblies may have switches or jumpers to set them up in specified configurations.

Refer to the Front View of the TM7000 (Figure 1.3.1) and the Rear View of the TM7000 (Figure 1.3.2) on the next page.

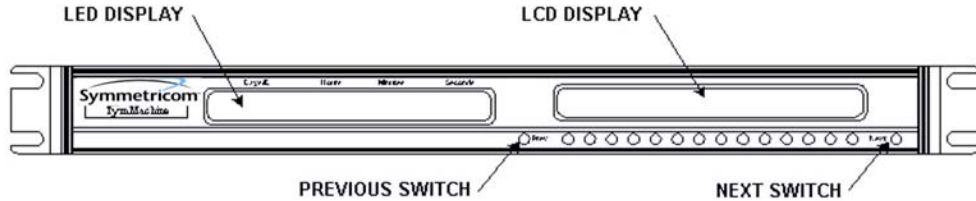

Figure 1.3.1
TM7000 TymMachine Front View

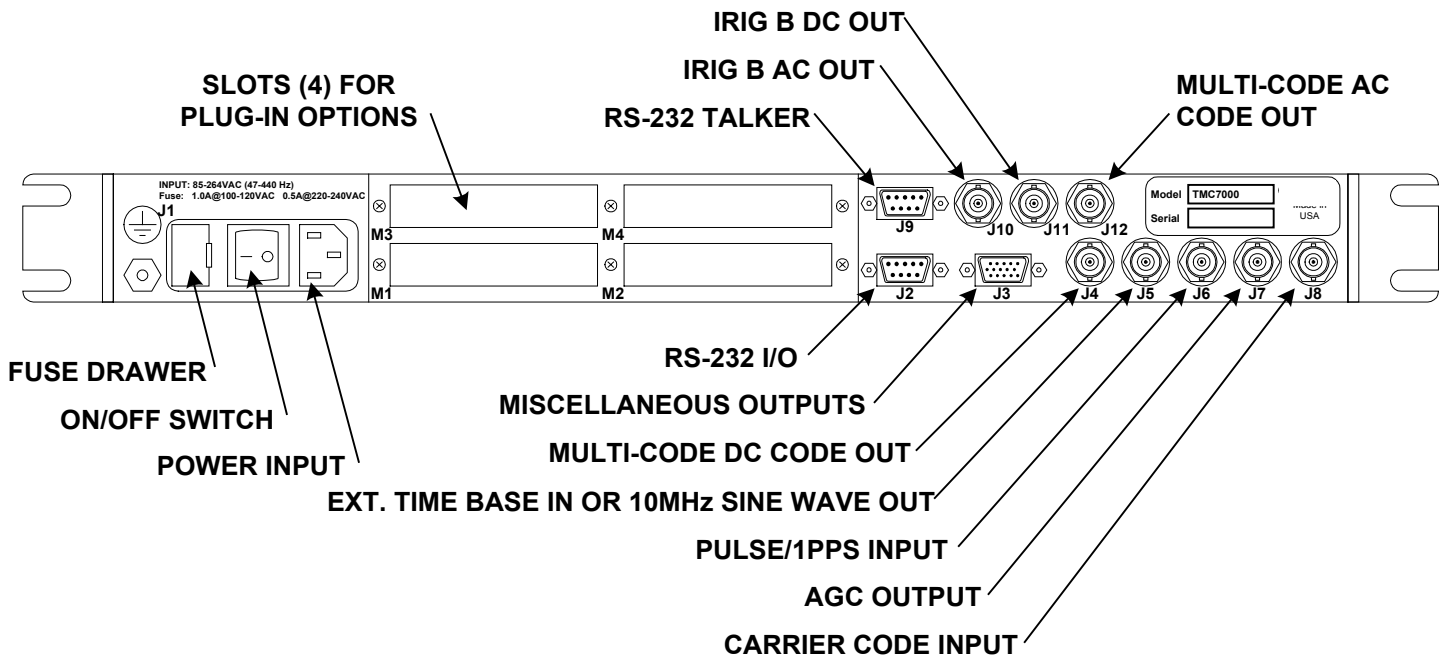

Figure 1.3.2
TM7000 TymMachine Rear View

1.4 SPECIFICATIONS

Refer to the following paragraphs and tables for the specifications applicable to the TymMachine. Changes or additions to these specifications, if any, are listed in Appendix A.

1.4.1 INPUTS

A. AC POWER (POWER ENTRY MODULE J1)

85 VAC to 264 VAC $\pm 10\%$
 47 - 440 Hz
 Less than 40 VA

The power supply used in this unit has an input range of 85 to 264 Volts. No jumpering required.

B. RS-232 INPUT/OUTPUT (9 PIN D CONNECTOR J2)

This I/O port provides remote control of operating functions in an ASCII protocol. BAUD rate, parity, word length, and stop bits are all selectable. Data is input to this interface through the TX line and output through the RX line. Time data can be output in either ASCII or Packed BCD formats. For operation, refer to Chapter Three.

Table 1-1 lists the connector pin assignments.

**Table 1-1
RS-232 I/O (J2)**

Pin Number	Designation
Pin 1	Not Used
Pin 2	RX
Pin 3	TX
Pin 4	DTR
Pin 5	Ground
Pin 6	DSR
Pin 7	RTS
Pin 8	CTS
Pin 9	Not Used

C. HIGH STABILITY EXTERNAL TIME BASE INPUT (BNC J5)

This external frequency input can be used to supply a high stability time base for the unit. The unit will use this external input, if connected, in place of the internal oscillator. The following Table 1-2 lists the input specifications:

**Table 1-2
High Stability External Sine Wave Input (J5)**

Frequency	1-10MHz.
Amplitude	1 volt peak-to-peak to 5 volts peak-to-peak square wave.
Input Impedance	50Ω, nominal.

Note: In order for this feature to operate, an internal jumper must be properly selected. See Operation, Chapter Three.

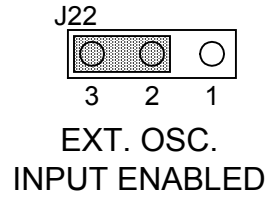

D. PULSE/1PPS INPUT (BNC J6)

This input pulse may be used for External Start or Tracking. Table 1-3 shows the characteristics for the Pulse Input at J6 if used.

**Table 1-3
Pulse/1PPS Input (J6)**

Format	1PPS TTL Pulse.
Pulse Width	1-999,999 microseconds.
Rise & Fall Times	Less than 1 microsecond.

E. CODE INPUT (BNC J8)

Table 1-4 lists the Code Input formats and Specifications for each, which are accepted by this unit.

**Table 1-4
Carrier Code Inputs (J8)**

Formats	IRIG A, B, E, G, H. NASA 28, 36. XR3, 2137, 1892, AN/GSQ-53.
Carrier Frequencies	IRIG A - 10kHz. IRIG B - 1kHz. IRIG E - 1kHz or 100Hz. IRIG G – 100kHz. IRIG H - 1kHz or 100Hz. NASA 28 100Hz. NASA 36 1Khz. XR3 250Hz. 2137 1kHz. 1892 1kHz. AN/GSQ-53 250Hz (Use XR3). AN/GSQ-53 1kHz (Use 2137).
Modulation Ratio	2:1 to 6:1.
Input Signal Level	0.1 volts to 10.0 volts peak-to-peak.
Input Impedance	Greater than 50kΩ, single-ended.
Frequency Range	30Hz to 2MHz.

1.4.2 OUTPUTS

A. MISCELLANEOUS OUTPUTS (15 PIN D CONNECTOR J3)

Table 1-5 lists the various pulse rates, codes, and alarm signals available on this multipin connector.

Table 1-5
Miscellaneous Outputs (J3)

SIGNAL	PIN #	SOURCE	DRIVE CAPABILITY
1KPPS	1	Generator	See Note 1
100PPS	2	Generator	See Note 1
10PPS	3	Generator	See Note 1
1PPS	4	Generator	See Note 1
Carrier	5	Translator	See Note 1
Carrier/10	6	Translator	See Note 1
Carrier/100	7	Translator	See Note 1
Carrier/1K	8	Translator	See Note 1
Ground	9	Generator	See Note 1
IRIG B DC Code	10	Generator	See Note 1
LOS Output*	11	Translator	See Note 1
ERR Output	12	Translator	See Note 1
	13		Not Used
	14		Not Used
	15		Not Used

Note 1: Outputs will drive a minimum of 4.0V into a 1K resistor to ground, or a maximum of 0.4V into a 1K resistor to +5V.

All Pulse Rates are 50/50% duty cycle, positive edge on-time.

* Input Threshold (LOSS) is adjustable from 0.5 to 10V P-P with a carrier frequency of 100Hz - 100kHz.

B. MULTICODE DC CODE OUTPUT (BNC J4)

This output produces a DC level shift serial code that contains the time value within the TM7000. It is generated by the Multi-Encoder section. The time code format is determined by front panel menu selection.

The DC code generated can be IRIG A, IRIG B, IRIG G, NASA 36, XR3, 2137 or AN/GSQ-53 as selected by the Output Code Menu. The time encoded may come from either the generator or the translator. Codes may be “re/generated” from the translator at multiple speeds.

Table 1-6 shows the specifications of the Multicode DC Serial Time Code output.

**Table 1-6
Multicode DC Code Output (J4)**

Format	Pulse Width Modulated.
Level	TTL/CMOS compatible.
Load	4mA sink

C. 10MHZ SINE WAVE OUTPUT (BNC J5)

A buffered output of the internal 10MHz oscillator is available on BNC J5. Table 1-7 shows the specifications of this 10MHz output.

**Table 1-7
10MHz Sine Wave Output (J5)**

Frequency	10MHz.
Amplitude	1 volt RMS (2.8 volts peak-to peak) when terminated into 50Ω.
Output Impedance	50Ω, nominal.

Note: In order for this feature to operate, an internal jumper (J22) must be properly selected as shown below:

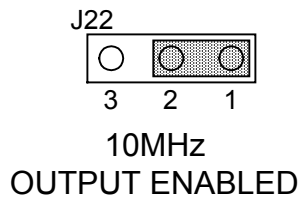

D. AGC (AUTOMATIC GAIN CONTROL) OUTPUT (BNC J7)

This code output is identical to the code input (J8) except that the amplitude is normalized at 2 volts peak to peak (no load) and 1 volt peak to peak into 50 ohms.

E. RS-232 TIME WORD OUTPUT – TALKER (9 PIN D CONNECTOR J9)

This printer output port can output data to an RS-232 compatible serial printer or terminal. The data (time and status) can be output in an ASCII or BCD format, selectable by DIP switches. Refer to Chapter Three for operation.

Table 1-8 lists the connector pin assignments.

**Table 1-8
RS-232 Talker (J9)**

Pin Number	Designation
Pin 1	Not Used
Pin 2	RX
Pin 3	TX
Pin 4	DTR
Pin 5	Ground
Pin 6	DSR
Pin 7	RTS
Pin 8	CTS
Pin 9	Not Used

F. IRIG B AC CODE OUTPUT (BNC J10)

Connector J10, the IRIG B (B120) Serial Time Code output from the Generator contains Time-of-Year plus CF (Control Functions) and STOD (Seconds Time-of-Day).

Table 1-9 shows the specifications of the IRIG B AC Serial Time Code output.

**Table 1-9
IRIG B (B120): BCD Time-of-Year (J10)**

Carrier Frequency	1kHz sine wave.
Amplitude	Adjustable from 0 to 5V Peak to Peak on the Mark Pulse.
Modulation Ratio	Adjustable, 3:1 nominal.
External Load	50Ω minimum.

G. IRIG B DC CODE OUTPUT (BNC J11)

Connector J11, the IRIG B (B000) Serial DC Level Shift Time Code output from the Generator contains Time-of-Year plus CF (Control Functions) and STOD (Seconds Time-of-Day).

Table 1-10 shows the specifications of the IRIG B DC Serial Time Code output.

**Table 1-10
IRIG B (B000): BCD Time-of-Year (J11)**

Format	Pulse Width Modulated B000.
Level	TTL/CMOS compatible.
Load	4mA sink

H. MULTICODE AC CODE OUTPUT (BNC J12)

This output produces an AC serial code that contains the time value within the TCG/T. It is generated by the Multi-Encoder section. The time code format is determined by front panel menu selection.

The AC code generated can be IRIG A, IRIG B, IRIG G, NASA 36, XR3, 2137 or AN/GSQ-53 (250 Hz) as selected by the Output Code Menu. The time encoded may come from either the generator or the translator. Codes may be “re/generated” from the translator at multiple speeds.

Table 1-11 shows the specifications of the Multicode AC Serial Time Code output.

**Table 1-11
Multicode AC Code Output (J12)**

Carrier Frequency	Dependant on code selected.
Amplitude	Adjustable from 0 to 5V Peak to Peak on the Mark Pulse.
Modulation Ratio	Adjustable, 3:1 nominal.
External Load	50Ω minimum.

1.4.3 INTERNAL TIME BASE

This unit can have one of two internal time bases depending on customer requirements. Unless otherwise specified, the following are the specifications for the oscillators used as the internal time base - not the specifications of the unit’s 10MHz sine wave output.

A. VCXO (VOLTAGE CONTROLLED TEMPERATURE COMPENSATED CRYSTAL OSCILLATOR) with the following specifications:

Output Frequency/Waveform
10MHz Sine Wave.

Aging Rate

±1.0PPM maximum per year.

Temperature Range and Stability

±1.0PPM from -30° to +75°C. (Note: This temperature range applies only to the crystal. The TCG/T is rated at 0° to +50°C.)

The following specifications are for the 10MHz sine wave output (2.8 volts peak-to-peak terminated into 50Ω) available on rear panel BNC connector J5:

Phase Noise

1Hz	-61 dBc/Hz
10Hz	-78 dBc/Hz
100 Hz	-97 dBc/Hz
1KHz	-116 dBc/Hz
10KHz	-124 dBc/Hz
100 KHz	-133 dBc/Hz

Harmonics

-10dBc max.

Spurious Noise

>-66dBc

B. LOW NOISE OVEN OSCILLATOR with the following specifications:**Output Frequency/Waveform**

10MHz Sine Wave.

Aging Rate

±5 x 10⁻¹⁰ per day, ±5 x 10⁻⁸ per year.

Temperature Stability

±1 x 10⁻⁸ over a temperature range of -20°C to +75°C. (Note: This temperature range applies only to the crystal. The TCG/T is rated at 0° to +50°C.)

Mechanical Frequency Adjust

±1PPM (minimum) / ±3PPM (maximum).

The following specifications are for the 10MHz sine wave output (2.8 volts peak-to-peak terminated into 50Ω) available on rear panel BNC connector J5:

Phase Noise

1Hz	-98 dBc/Hz
10Hz	-124 dBc/Hz
100Hz	-135 dBc/Hz
1KHz	-136 dBc/Hz
10KHz	-137 dBc/Hz
100KHz	-138 dBc/Hz

Harmonics

-45 dBc

Spurious Noise

>-70 dBc

1.4.4 ENVIRONMENT

Table 1-12 shows the Environmental specifications of this unit.

**Table 1-12
Environmental Specifications**

Temperature	0°C to +50°C Operating. -20°C to +55°C Storage.*
Humidity:	Up to 95% Relative.

* Long Term Storage (1 year, -20°C to +35°C)

Because the TM7000 contains a battery, when storing for more than 1 year, charge at least once a year (i.e. turn on the unit and let it run for at least 24 hours) to prevent battery leakage and deterioration in performance due to self-discharging.

1.4.5 SIZE AND CONFIGURATION

Table 1-13 shows the physical size and configuration of the TymMachine.

**Table 1-13
Size and Configuration**

Chassis, TM7000	Height 1 ¾" Width 19" Depth 18"
Mounting	Standard 19" equipment cabinet

1.5 SAFETY PRECAUTIONS AND HEALTH HAZARDS

With normal handling, this product contains no materials, which could cause any health hazards.

This product utilizes low voltages which in themselves cause no personal safety problems with the exception of the AC Power input voltage, and voltages within the Power Supply.

The following “CAUTION” label will appear in this manual where precautionary measures should be taken.

***** CAUTION *****

The AC Power input module utilizes a power supply which has an input range of 85 to 264 volts. This voltage is only exposed to personnel when the Top Cover of the unit is removed. This High Voltage exists in the right rear corner of the unit as viewed from the front.

This Page Intentionally Left Blank

CHAPTER TWO

INSTALLATION

2.0 INTRODUCTION

This section provides an installation procedure for the TM7000 TymMachine Time Code Generator/Translator (TCG/T).

2.1 INSTALLATION PROCEDURE

Upon receiving the TymMachine, make a thorough inspection of the instrument and all its accessories. Any damage or loss of equipment should be reported immediately to the responsible carrier. If no damage is found, install the TymMachine as outlined in the following steps:

2.2 PRE-INSTALLATION CHANGES (IF DESIRED)

Before shipping, the TymMachine was configured for the anticipated use. If the user wishes to make any changes this can most conveniently be done before installation. See the Top Assembly Drawing for the location of assemblies. (The Top Cover of the unit needs to be removed to access any of the jumpers or internal switches.)

2.2.1 POWER SUPPLY

The Power Supply in this unit has an input operation range of 85 to 264 Volts AC 47 to 440 Hz therefore no jumpers are required.

2.2.2 SYNCHRONIZED TIME CODE GENERATOR ASSEMBLY 100007 (refer to Figure 2.2)

A. REAR PANEL BNC J5 CONFIGURATION

Internal jumper J22 provides selection of J5 (rear panel BNC) as an external oscillator input or a 10MHz sine wave output.

Note: The factory default setting for this jumper is Ext. Osc. Input Enabled.

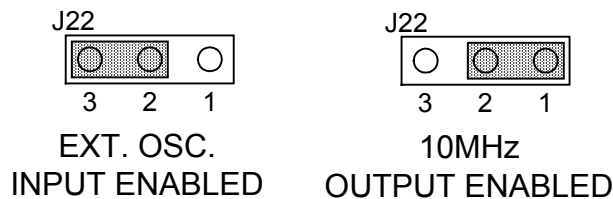

CHAPTER TWO

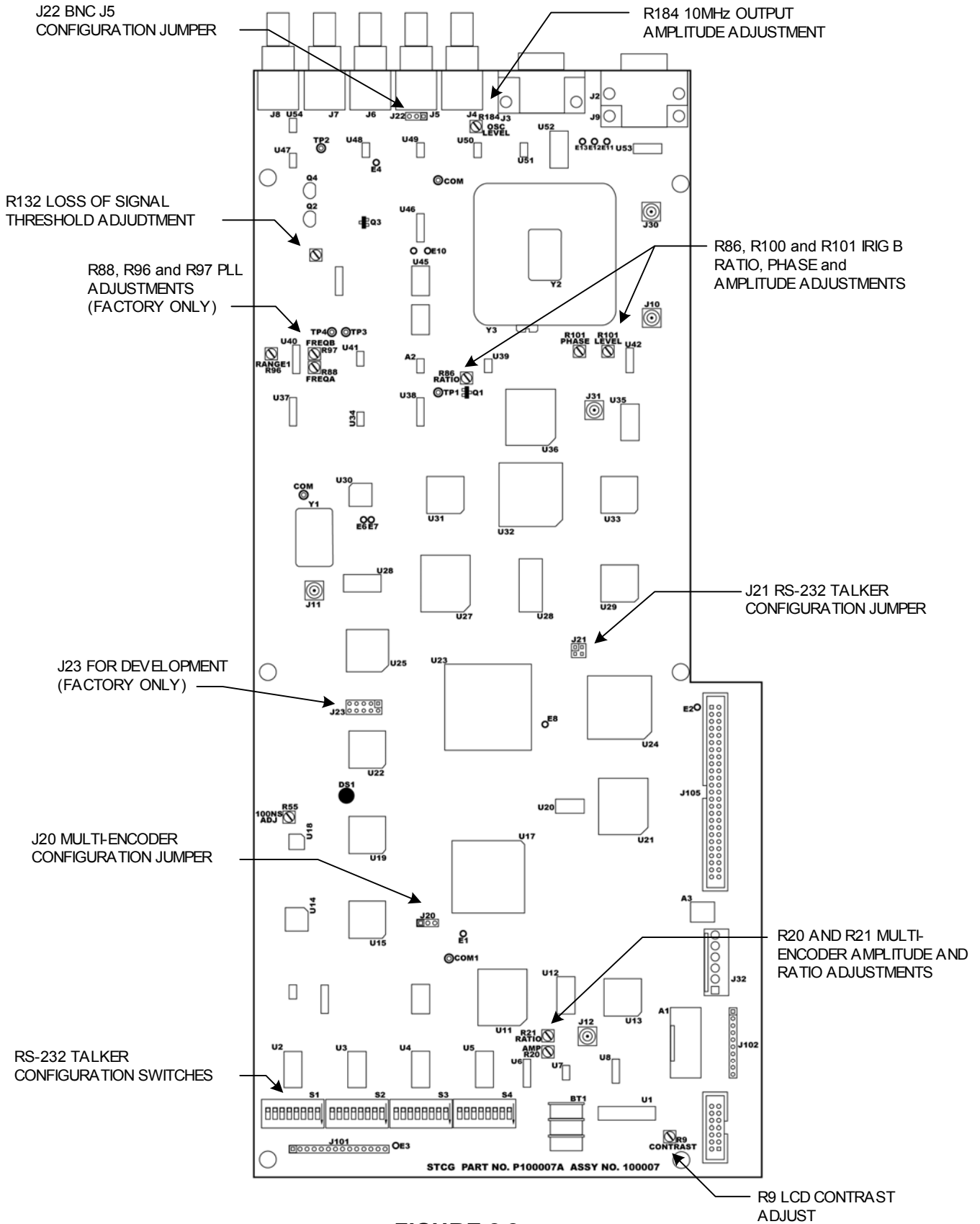
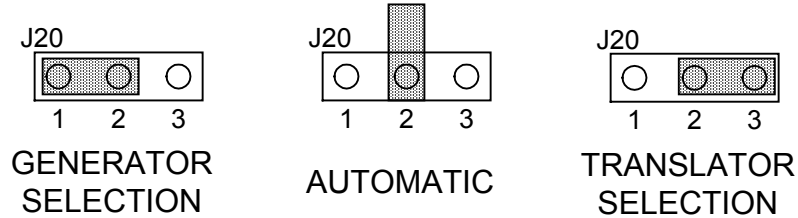

FIGURE 2.2

B. REAR PANEL BNC J4 AND J12 CONFIGURATION

Internal jumper J20 configures the Multi-Encoder outputs to contain either the generated time, the translated time, or in the automatic mode (with no jumper) to contain the time displayed on the LED Display. Rear panel BNC J4 is the Multi-Encoder DC output, and J12 is the Multi-Encoder AC output.

Note: The factory default setting for this jumper is Automatic.



Note: Power must be cycled for a jumper change to be effective.

C. REAR PANEL J9 (9-PIN D CONNECTOR) CONFIGURATION

Internal jumper J21 configures the RS-232 Talker to output either the generated time, the translated time, or in the automatic mode to output the time displayed on the LED Display.

Note: The factory default setting for this jumper is Automatic.

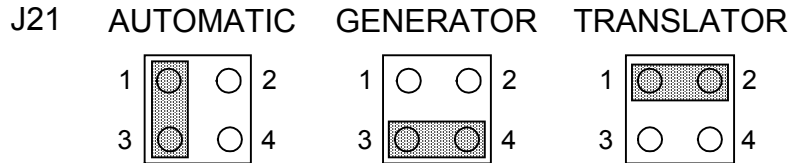

Note: The mode, number of bits in the output word, BAUD rate, parity etc. of the RS-232 Talker should be changed at this time if desired. Refer to Chapter Three.

2.3 RACK MOUNTING PROCEDURE

The TymMachine is designed for standard nineteen inch rack mounting.

Optional chassis slides are recommended if the unit is to be installed in an equipment rack. Refer to Figure 2.3. If slides are not used, a supporting bar or tray should be provided for the rear of the instrument. The chassis slides attach to the sides of the TymMachine. To mount it using the optional slide mounting kit, use the #6 self tapping screws provided with the kit.

FIGURE 2.3

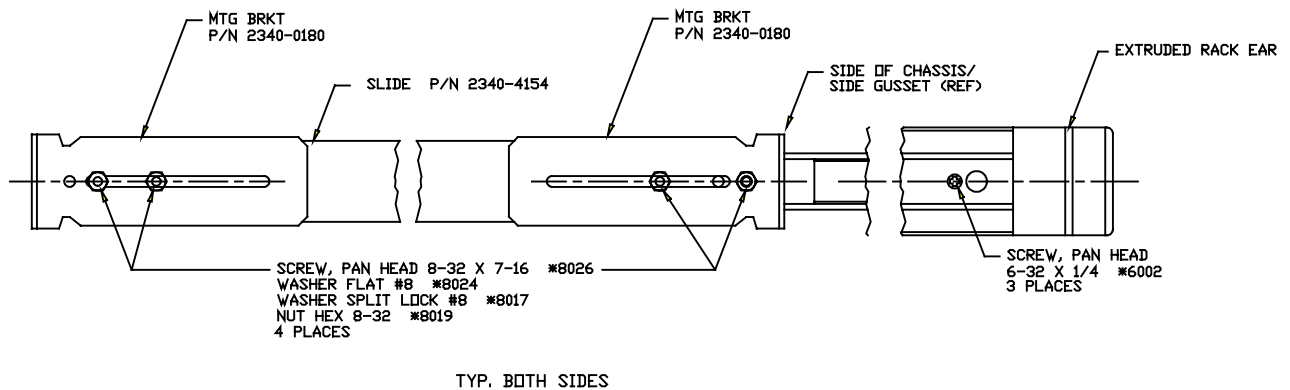

*** CAUTION ***

General Cautions/hazards to be considered when installing the TymMachine into an equipment rack:

- 2.3.1 TMRA** - The maximum recommended ambient temperature (Tmra) that this equipment is specified to operate at is +50°C.
- 2.3.2 ELEVATED OPERATING AMBIENT TEMPERATURE** - If installed in a closed or multi-unit rack assembly, the operating ambient temperature of the rack environment may be greater than room ambient. Therefore, consideration should be given to installing the equipment in an environment compatible with the maximum rated ambient temperature (Tmra).
- 2.3.3 REDUCED AIR FLOW** - The equipment has no cooling fans and depends on convection for cooling. Installation in a rack may cause an excessive heat rise if sufficient air flow is not available. Installation should be such that the amount of air flow required for safe operation of the equipment is not compromised.
- 2.3.4 MECHANICAL LOADING** - Mounting of the equipment in the rack should be such that a hazardous condition is not achieved due to an uneven mechanical loading.
- 2.3.5 CIRCUIT OVERLOADING** - Consideration should be given to the connection of the equipment to the supply circuit and the effect that overloading of circuits may have on over current protection and supply wiring. Appropriate consideration of equipment ratings should be used when addressing this concern.
- 2.3.6 RELIABLE EARTHING** - Reliable earthing of rack-mounted equipment should be maintained. Particular attention should be given to supply connections other than direct connections to the branch circuit (e.g., use power strips, chassis ground lug etc).

2.4 CONNECTIONS – See Rear View TM7000, Figure 2.4

Rear panel connectors J4, J5, J6, J7, J8, J10, J11 and J12 are BNC type connectors. Mating connectors are not provided with the TymMachine, as the type used depends upon the type of coaxial cable used.

Connector J3 is a 15 pin “D” type connector, DA-15P Cannon or equivalent. The mating connector is provided with the TymMachine.

Connectors J2 and J9 are 9 pin “D” type connectors. Because the mating connectors and cables (1 to 1) are readily available, they are not furnished with the TymMachine.

Make all connections to the TymMachine rear panel and Option assemblies as follows:

- a. Ensure that the POWER switch is in the OFF position. Connect a primary power source to power input connector on rear panel of the TymMachine power entry module, using the Power Cord provided.
- b. Make appropriate connections to TymMachine Input/Output connectors to the rear panel of the TymMachine as well as any Option Assemblies.

Note: Input /Output cable assemblies are not supplied, and must be fabricated, using the connector plugs supplied with the TymMachine. Refer to Chapter One and the Option Description(s) for connector type, J-numbers and pin assignments.

- c. Connect a Carrier Modulated Code to the input connector (J8) if desired.
- d. An External Frequency, any integer of 1 through 10 MHz (1, 2, 3 MHz, etc.) input to the TymMachine, at rear panel BNC connector J5, may be used to operate the TymMachine in lieu of the internal oscillator.

Note: This input must be TTL Square Wave or Sine Wave with a minimum amplitude of 1 volt Peak-to-Peak and a maximum of 5 volts Peak-to-Peak into a 50 Ohm load.

- e. If the TymMachine is to be used as a Tape Search Control Unit, connect the Tape Search output connector to the reproducer.
- f. The unit is now ready for operation

Rear View TM7000
Figure 2.4

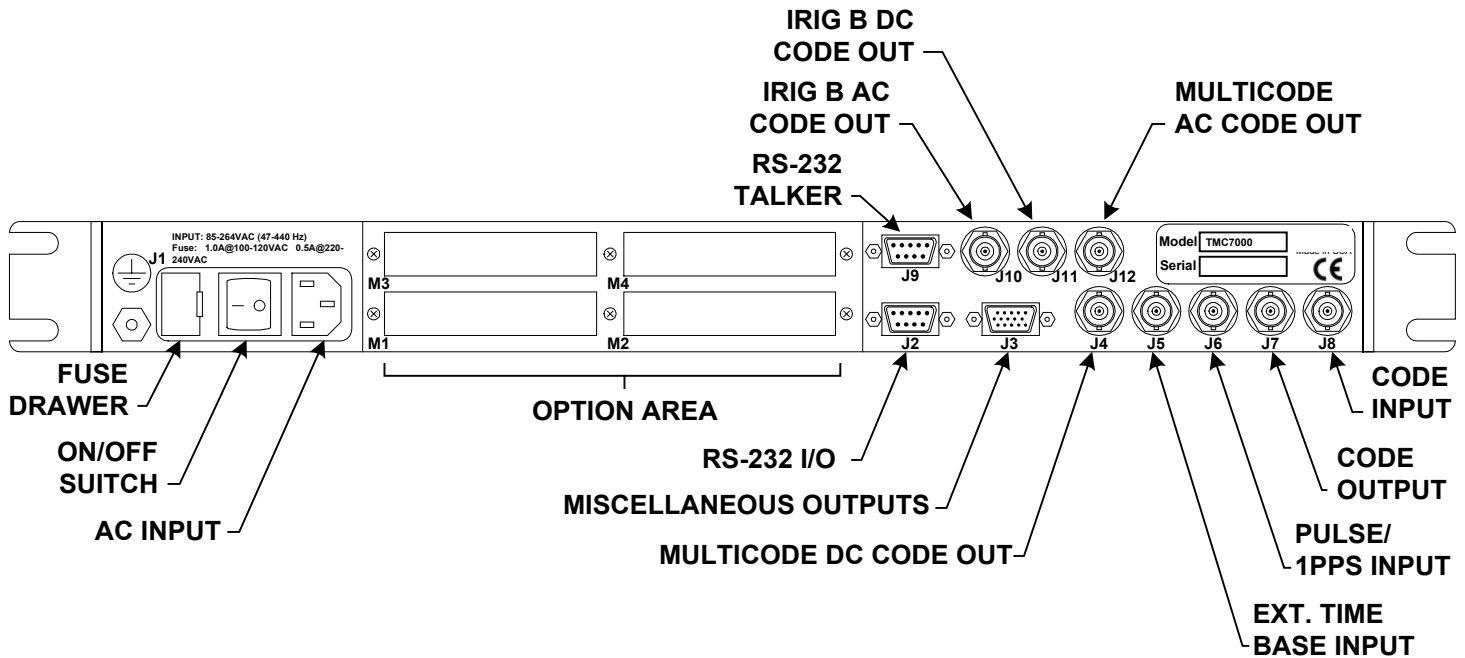

2.5 OPTION CARD INSTALLATION PROCEDURE

The following procedure should be adhered to when installing any option card assembly:

- a. Disconnect power from the TymMachine.
- b. Option cards are installed in the rear panel option areas labeled M1 to M4. Remove the six screws that hold the Rear Panel Option Plate and the Option Plate Blanks to the chassis. Refer to Figure 2.4.
- c. Configure and verify the settings of the option card. Refer to the Option Description supplied with the card or furnished in Appendix A of this User's Guide.
- d. Insert the module into the selected option slot, being careful that the components are on the upper side of the module. Make sure the option card is firmly seated in the connector.
- e. Reinstall the Rear Panel Option Plate. Using the six screws, attach the Option Plate (furnished with the Option Card) and any remaining blank panels through the Rear Panel Option Plate to the metal chassis card guides.
- f. Attach any applicable I/O cables, and apply power to the unit.

CHAPTER THREE

OPERATION

3.0 INTRODUCTION

The TymMachine TM7000 features two independent displays, an LED Time display and a LCD Display (MENU) of instrument function and user selections. Immediately below the LCD Display are sixteen push-button switches. The switches at either end are used to select the next or previous menu. The remaining fourteen switches are used to make selections from the menu.

In many cases when a selection is made, the menu is automatically changed to the next menu. If the operator wishes to retain the previously made selection, he may simply press the NEXT switch. Once made, a selection remains in memory indefinitely until changed by the operator.

3.1 CONTROLS AND INDICATORS

With the exception of the POWER switch (located on the rear panel Power Entry Module), all of the normal operating controls of the TM7000 are located on the front panel. Their purposes and functions are described in the following paragraphs.

Note: The outputs, jumper selections, potentiometers etc. described in this Operation Chapter are derived from and located on the Synchronized Time Code Generator (STCG), Assembly 100007.

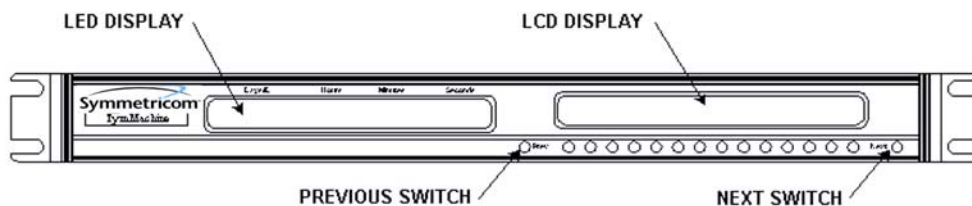

TM7000 Front Panel

Figure 3.1

3.2 CONTROLS

The following is an explanation of the controls used in this unit:

3.2.1 POWER SWITCH

The POWER Switch is rocker type switch, located on the rear panel Power Entry Module of the unit. It controls application of AC power to the unit. The internal battery for backup time keeping is not controlled with this switch.

CHAPTER THREE

3.2.2 NEXT SWITCH

The NEXT switch is used to change the LCD Display to the next menu. When the end of a series of menus is reached, this switch selects the menu most likely to be used next. Of the block of 16 LCD Display switches, the NEXT switch is the one on the extreme right (as viewed from the front). See Figure 3.1.

3.2.3 PREV SWITCH

The PREV switch is used to change the LCD Display to the previous menu. Of the block of 16 LCD Display switches, the PREV switch is the one on the extreme left (as viewed from the front). See Figure 3.1.

3.2.4 SELECT SWITCHES

The remaining 14 switches, located between the NEXT and PREV switches (See Figure 3.1), are used to make the selections within a menu. Most menus have a function on the top line, and selections on the bottom line. The bottom line thereby identifies the purpose of the SELECT switches. The purpose of these switches change when the menu changes. When two or more switches are below a legend, any one of them may be used for that selection.

3.2.5 INTERNAL JUMPERS (LOCATED ON ASS'Y 100007) - Refer to Figure 2.2 in Chapter Two

A. J21 RS-232 TALKER OUTPUT SELECT

This jumper configures the RS-232 Talker to output translated time, generated time, or in the automatic mode, to generate the time displayed on the front panel LED Display.

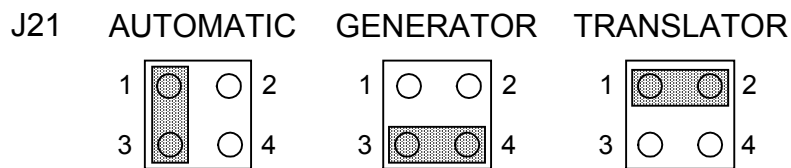

Note: The factory default setting for this jumper is Automatic.

B. J20 MULTI-ENCODER OUTPUT SELECT

This jumper configures the Multi-Encoder to output translated time, generated time, or in the automatic mode (with no jumper installed), to generate the time displayed on the front panel LED Display.

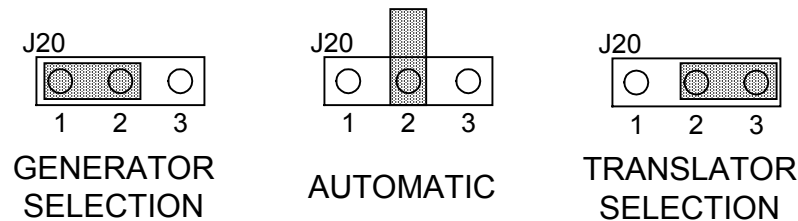

Note: The factory default setting for this jumper is Automatic. Power must be cycled for a jumper change to be effective.

C. J22 REAR PANEL BNC J5 CONFIGURATION

Internal jumper J22 provides selection of J5 (rear panel BNC) as an external oscillator input or a 10MHz sine wave output.

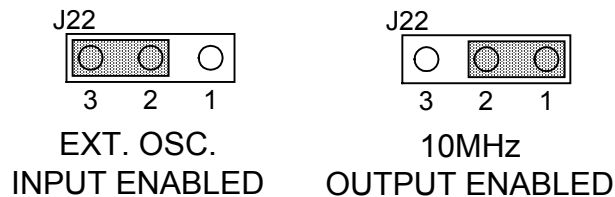

Note: The factory default setting for this jumper is Ext. Osc. Input Enabled.

3.3 INDICATORS

The following paragraphs give an explanation of the indicators used in this unit:

3.3.1 LCD DISPLAY

The LCD Display is used to display menus for operator prompting, instrument status, and the function of the select switches. The LCD Display is located on the right half of the front panel just above the SELECT switches. See Figure 3.1.

3.3.2 LED DISPLAY

The LED Display is normally used to display Time-of-Year. The time displayed is automatically selected from the Generator or the Translator according to the menu chosen. The LED Display is located on the left half of the TM7000 front panel. See Figure 3.1.

3.4 OPERATING PROCEDURES

This section contains operating procedures for the TM7000. All units are capable of operation in the GENERATOR or TRANSLATOR mode. Those supplied with the Tape Search Option can also operate in the TAPE SEARCH mode. Selection of any optional mode not supplied results in the LCD Display changing to that shown in Figure 3.4.1. Pressing any switch will exit this menu.

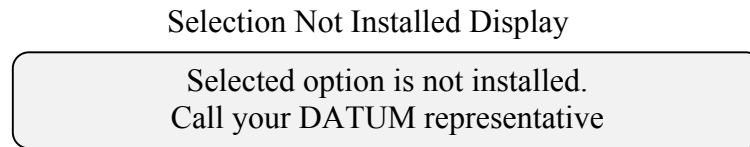

Figure 3.4.1

3.5 POWER ON/OFF

Push the rear panel POWER switch to the ON position to activate the unit. (Push the side of the rocker switch indicated by “-”).

To remove power from the unit, push the POWER switch to the OFF position. (Push the side of the rocker switch indicated by “o”).

Note that the POWER switch has no effect on the internal backup time keeping circuitry, although POWER must be ON to charge the backup battery.

When power is first applied to the unit, a self-test and diagnostic procedure is performed. During the several seconds this takes, the condition of the displays are indeterminate. Following self test, the Versatile Display Function Menu, as shown in Figure 3.5.1, will be displayed on the LCD Display. The LED Display will indicate Time-of-Year if the Generator is running. If stopped, a LED test will be performed, and then day one will be displayed. Any other display indicates a failure.

In units equipped with the Power On Translate option, the LCD Display will display the menu as shown in Figure 3.5.2, and Translator time will appear on the LED Display.



Figure 3.5.1

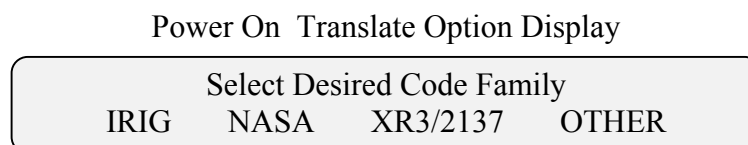

Figure 3.5.2

3.6 INITIAL MENU SELECTIONS

The SELECT switches provide manual control of the TM7000. The function of these switches changes when the menu is changed. The menu may be changed by pressing the NEXT switch, the PREV switch, or one of the select switches.

The progression of menus is broken into logical sequences for the three distinct functions of the TM7000: Generator, Translator, and Tape Search (Optional). In order to avoid operator confusion, the menus corresponding to options, which are not included in a specific unit configuration, are not accessible to the user. If selected, the message shown in Figure 3.4.1 will appear on the LCD Display. Menus for the RS-232 I/O are accessed from the Generator Menu. The menus relating to the hardware options are presented with the Option Descriptions in Appendix A.

In some instances, a menu selection requires a mode change in the unit. For example, going from GENERATOR to TRANSLATOR. The following Warning Message shown in Figure 3.6.1 will appear to remind the user of a mode change:

Warning Message

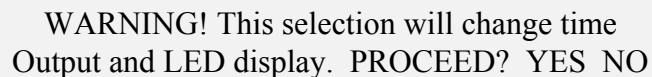

WARNING! This selection will change time
Output and LED display. PROCEED? YES NO

Figure 3.6.1

The unit will only proceed to a different mode if YES is selected from this menu. If NO is selected, the unit will revert to the previous menu and the mode will remain intact.

In this chapter each menu will be depicted. The menus, which may be accessed from this initial menu, are shown below it, along with explanatory text, when additional clarity is needed.

Once a set-up parameter has been input, i.e. Translate IRIG B, that menu may be subsequently skipped over by continuously pressing the NEXT switch. Tape searching is stopped when the AUTO-S or MAN-S menus are exited. The new user is encouraged to experiment with the selection of the different menus and operating modes.

3.6.1 CHANGE DISPLAY FORWARD OR BACKWARD

To change from an existing display (menu) to the next display, press the NEXT switch located on the front panel. To go back to a previous display, press the PREV(ious) switch located on the front panel.

3.6.2 EXPLANATION OF SWITCH

The top line of the display will show the switch function such as Select Generator Mode. The bottom line is the selection to be made such as SET-UP or OPERATE. See Example Figure 3.6.2.1.

Example

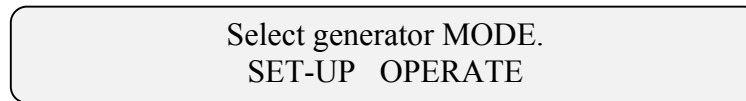

Figure 3.6.2.1

3.6.3 INTRODUCTION TO SELECT SWITCHES

The switches are used to make the selection desired from a menu screen. See Figure 3.6.3.1 for an example of using the switches.

Example

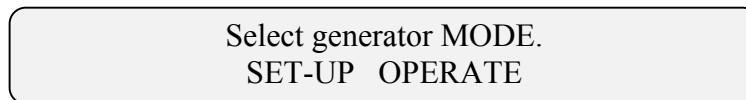

Figure 3.6.3.1

The example shows the Generator Select Mode select Screen. If either of the switches directly below SET-UP is pressed, access to the SET-UP Generator menu screen will appear on the LCD Display. Pressing either of the switches directly below OPERATE will select the OPERATE Generator menu screen to appear on the LCD Display.

Pressing the NEXT switch will advance the LCD display to the Select Versatile Display Function Menu screen shown in Figure 3.6.4.1.

3.6.4 VERSATILE DISPLAY FUNCTION MENU

This display, the Versatile Display Function Menu, allows the user to select the mode of operation in which the TM7000 is to operate.

Versatile Display Function Menu



Figure 3.6.4.1

Selecting GENERATOR from the menu by pressing any key beneath GENERATOR will result in the Select Generator Mode display, Figure 3.7.1 in Paragraph 3.7 being displayed.

Depressing any of the switches under TRANSLATOR causes the LCD Display to change to the Warning Message, Figure 3.6.1. This is prior to entering the Set-up Translator Menu, Figure 3.8.1 in Paragraph 3.8 Translator Operation.

Selection of the TAPE SEARCH mode of operation is accomplished by pressing any of the switches under TAPE SEARCH. Selecting TAPE SEARCH will change the LCD Display to the Warning Message, Figure 3.6.1, prior to entering the Select Tape Search Mode Menu screen. This will only occur if the Tape Search option assembly, TM Option 02/02A is installed. If this option is installed, see TM 02/02A Option Description, located in Appendix A.

3.7 GENERATOR OPERATION

The initial menu, as shown in Figure 3.7.1, for the Generator Function requires the user to choose between SET-UP and OPERATE modes. The Generator Time is displayed on the LED Display whenever a Generator function is displayed on the menu. When powered down with the Generator stopped, it will power up stopped and time set to day one, so you can go directly to the SETUP menu and preset the time. Conversely if the Generator is running, it may be desirable to go to the OPERATE menu and stop the Generator before presetting time. It is not necessary to stop the Generator to preset time, so a shift to daylight savings time (for example) can be easily accomplished.

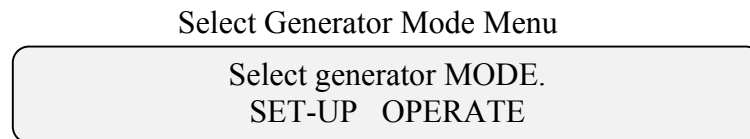

Figure 3.7.1

Using either of the switches below SET-UP will change the LCD Display to that shown in Figure 3.7.7.1 for user use in controlling the Generator.

Pressing the PREV switch will return the LCD Display to the Versatile Display Function Menu, Figure 3.6.4.1.

3.7.1 GENERATOR OPERATE MENU

Using either of the switches below OPERATE will change the LCD Display to that shown in Figure 3.7.1.1.

This menu provides controls for starting and stopping the Generator, and access to menus for manual or automatic synchronization. To start the generator press the START switch, located beneath START. To stop the Generator the two stop switches must be activated in sequence, STOP (1) then STOP (2). When stopped, the sub-seconds time is set to zero or to the amount of propagation delay.

Generator Operate Menu



Figure 3.7.1.1

Pressing the NEXT or PREV switch while this menu is displayed will return the LCD Display to the Select Generator Mode Menu shown in Figure 3.7.1.

Access to the Advance/Retard Menu can be obtained by pressing the appropriate switches below the desired function. See Paragraph 3.7.2.

Access to the SYNC Select Menu is accomplished by pressing the switch beneath “SYNC”. This leads to the SYNC Select Menu being displayed on the LCD display as shown in Figure 3.7.1.2.

SYNC Select Menu



Figure 3.7.1.2

The SYNC-&-VERIFY selection is made by pressing any switch under SYNC-&-VERIFY. See Paragraph 3.7.4, Sync & Verify Operation, for an explanation of the Sync-&-Verify selection.

Selecting 1PS-TRACKING will change the LCD Display to the 1PPS Tracking Control Menu. See Paragraph 3.7.5 and Figure 3.7.5.1.

3.7.2 ADVANCE/RETARD OPERATION

Selecting ADV/RET from the menu screen shown in Figure 3.7.1.1 changes the LCD to the ADV/RET Menu Screen shown in Figure 3.7.2.1.

This menu provides the controls for manually advancing or retarding the time generated by the TM7000. First select the desired rate, which will be indicated by a blinking digit, then press a switch under ADV or RET until the desired positioning has been achieved. If necessary, the rate can be changed and the procedure repeated.

ADV/RET Menu Screen



Figure 3.7.2.1

The Advance/Retard Rate is changed by depressing the switch under the desired rate .1, 1, 10, 100 etc. This will cause the selected rate to blink.

Pressing the NEXT or PREV switch changes the LCD Display to the Generator Operate Menu, Figure 3.7.1.1.

3.7.3 SYNC GEN OPERATION

Selecting SYNC GEN from the Sync Select Menu, Figure 3.7.1.2 results in the Sync-Gen Menu screen; Figure 3.7.3.1 being displayed on the LCD Display.

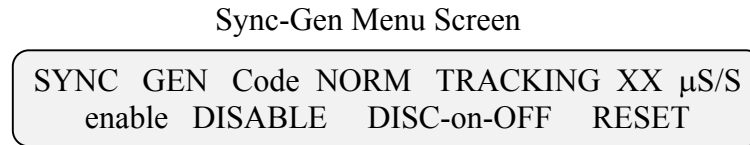

Figure 3.7.3.1

This menu is used to control the synchronized generator and to indicate a LOSS or NORM(al) level of code into the Translator. Input for the Sync Gen operation comes from the code input to the Translator. The Sync Gen function may be enabled or disabled using the appropriate switch. Tracking continues at the rate stored when a loss of input occurs if enabled. The stored rate may be reset, by depressing the switch below RESET.

The oscillator discipline function can be enabled or disabled. The DISC - ON - OFF switches control the function. The SYNC GEN must be enabled for disciplining to operate in the SYNC GEN mode. Disciplining provides an analog voltage for control of the internal oscillator. It will not work with the external oscillator. DISC - ON - OFF also functions with 1PPS Tracking if enabled.

The internal oscillator may be adjusted while tracking to minimize the tracking rate. See Chapter Five.

If the oscillator is disciplined or the unit is cold, several seconds (or minutes) are required for the oscillator to settle.

The menu displayed in Figure 3.7.3.1 shows input code to be normal, SYNC GEN to be disabled, and disciplining to be OFF. If the proper code input level was not present, Loss would be shown after Code.

Enabling or Disabling the SYNC-Gen mode is accomplished by pressing a switch under the desired mode. The selected mode will appear in upper case letters.

To set Disciplining ON or OFF press the switch directly below the desired function and the display will change the selected mode to upper case letters.

CHAPTER THREE

3.7.4 SYNC & VERIFY OPERATION

See SYNC Select Menu, 3.7.1.2.

This selection initiates a synchronizing sequence. The TM7000 can synchronize to IRIG A, IRIG B, or any 1KHz carrier, one frame per second code which the unit translates. The code is applied to the Translator Code Input (J8) and must be selected on the Translator Code Select Menu.

***** CAUTION *****

Attempting to Sync and Verify to a code not selected (i.e. the input to the Translator is different than that selected) can cause the Generator to lock-up. If this happens perform a Manual System Reset, See Chapter Five, Section 5.3.5.

A message showing “synchronizing” will be displayed on the LCD Display while the unit is synchronizing to the input code and “synchronized” will appear momentarily when synchronization is complete. The LCD Display will then return to the SYNC Select Menu, Figure 3.7.1.2.

If the input is bad or has not been properly selected a fault message will appear.

Pressing the NEXT or PREV switch changes the LCD Display to the Generator Operate Menu, Figure 3.7.1.1.

3.7.5 1PPS TRACKING OPERATION

See SYNC Select Menu, Figure 3.7.1.2.

The selection of the Tracking Edge is under menu control and Prop Delay may be used to offset the Generator. Tracking is enabled or disabled by use of the appropriate switch.

1PPS Tracking requires that a 1PPS, TTL level, signal be connected to rear panel BNC connector J6.

Selection of 1PS-Tracking from the SYNC Select Menu, Figure 3.7.1.2, will cause the LCD Display menu to be as shown in Figure 3.7.5.1.



Figure 3.7.5.1

Selecting the ON-TIME Edge is accomplished by pressing any switch below the desired edge, either Positive (rising) or Negative (falling). The ON-TIME Edge selected will be shown in upper case letters on the LCD Display.

1PPS TRACKING may be turned either ON or OFF by depressing the switch below either ON or OFF. The selected 1PPS TRACKING mode ON or OFF will be displayed in upper case letters.

Pressing the NEXT or PREV switch changes the LCD Display to the SYNC Select Menu, Figure 3.7.1.2.

3.7.6 GENERATOR SET-UP

Selecting SET-UP from the Select Generator Mode Menu, Figure 3.7.1, leads to the Generator Set-Up Menu screen shown in Figure 3.7.6.1.

This menu provides a selection of other menus to set-up the Generator and the Computer I/Os.

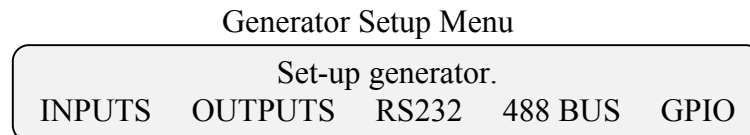

Figure 3.7.6.1

Selecting NEXT will revert the LCD Display to that shown in Versatile Display Function Menu, Figure 3.7.6.2.

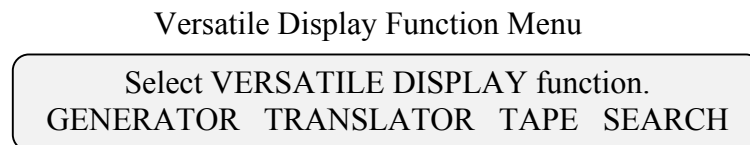

Figure 3.7.6.2

Selecting PREV will revert the LCD Display to that shown in Figure 3.7.6.3, the Select Generator Mode Menu.

Select Generator Mode Menu

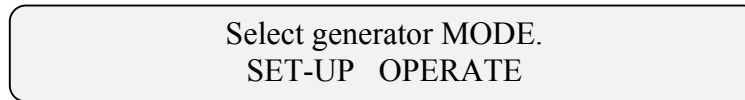

Figure 3.7.6.3

3.7.7 GENERATOR SET-UP INPUTS

From the Generator Set-Up Menu, Figure 3.7.7.1, the Select Generator Inputs Menu will appear on the LCD Display when “INPUTS” is selected as shown in Figure 3.7.8.1.

Set-Up Generator Inputs Menu



Figure 3.7.7.1

This menu is used to select a menu to input data to the Generator. The four choices permit presetting Time-of-Year (TIME), presetting Propagation Delay (PROP DELAY), inputting Control Functions (CNTRL FUNC), or preparing the TM7000 for an External Start Input (EXT START).

3.7.8 INPUTTING TIME

Selecting “TIME” from the Set-Up Generator Inputs Menu, Figure 3.7.7.1, by pressing a switch below TIME will generate the Preset Time Display Menu shown in Figure 3.7.8.1 on the LCD Display.

Preset Time Display Menu

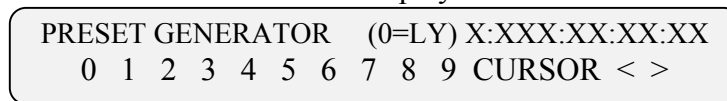

Figure 3.7.8.1

This menu is used for setting Time-of-Year into the Generator.

Presetting is accomplished by using the switches, located under the numbers, for numbers zero through nine, and the cursor left “<” and cursor right “>” switches.

When this menu is selected, the cursor will be positioned at the far left (Leap Year) position. When a digit is entered, the cursor automatically moves right to the next digit. If desired, the cursor may be moved without changing a digit by use of the cursor right or left switches. The cursor wraps around at either end.

It is the operator's responsibility to ensure that only legal times are entered. Leap Year days radix is provided for by the LY digit left of days. This digit should be 0-3, 0 during Leap Year, 1 the next year, etc. This digit is automatically incremented each year.

Pushing NEXT from this menu will advance to the Generator Operate Menu, Figure 3.7.8.2 allowing the user to start the Generator immediately.

Generator Operate Menu

To STOP generator press 1 release then 2
STOP(1) START STOP(2) ADV/RET SYNC

Figure 3.7.8.2

Pushing the PREV while the Preset Time Menu is displayed will return the LCD Display to the Set-Up Generator Inputs screen, Figure 3.7.7.1.

3.7.9 INPUTTING PROPAGATION DELAY

The Set Propagation Delay screen as shown in Figure 3.7.9.1 is displayed on the LCD Display when it is selected from the Select Generator Inputs Menu.

Set Propagation Delay Screen

Select desired PROP DELAY (mS) +XXX.XXXX
0 1 2 3 4 5 6 7 8 9 CURSOR < >

Figure 3.7.9.1

Any propagation delay (or advance) compensation between -4.999mS and $+997.0000\text{ mS}$ (milliseconds) may be selected. Moving the cursor left through the sign (+ or -) will change it. The Generator must be stopped to enter a Propagation Delay.

When this menu is selected, the cursor will be on the far left digit next to the (+) sign. Digits for the desired PROP DELAY are entered using the switches located under the numbers 0 through 9. When a digit is entered, the cursor automatically moves right to the next digit. If desired, the cursor may be moved without changing a digit by use of the cursor right ">" or cursor left "<" switches. The cursor wraps around at either end.

3.7.10 SETTING CONTROL FUNCTIONS

When Control Functions (CNTL FUNC) is selected from the Select Generator Inputs Menu, shown in Figure 3.7.8.1, the LCD Display will change to show the Control Function Bit Display (1) as shown in Figure 3.7.10.1.

CHAPTER THREE

Control Functions entered from these screens are inserted into the Serial Time Code Output of the basic TM7000. They are also output via the Control Function Outputs option if installed.

A “0” represents the OFF condition of the Control Function Bit and a “1” represents the ON condition.

Pressing the switch below a Control Function Bit number will change it to a “1” if it is a “0” or to a “0” if is a “1”.

Up to three groups of nine bits of Control Functions may be accessed. Control Function Bit Display (1) is the first.

Control Function Bit Display (1)

TOGGLE CF BIT	0	1	2	3	4	5	6	7	8
	0	1	0	1	0	0	1	1	0

Figure 3.7.10.1

Pressing the PREV switch while this display is shown will return the LCD Display to the Set-Up Generator Inputs Menu screen.

Pressing the Next switch will change the LCD Display to show Control Function Bits 9 through 17, which allows for setting Control Function Bits 9 through 17.

Pressing the NEXT switch while Control Function Bits 9 through 17 are shown will change the Control Function Bits to 18 through 26 allowing them to be changed.

Pressing the PREV switch while any of the above screens are shown will change the LCD Display to the last (previous) screen shown.

Pressing NEXT while Control Function Bits 18 through 26 are shown will cause the LCD Display to return to the Set-Up Generator Inputs Menu screen, Figure 3.7.8.1.

3.7.11 EXTERNAL START PROCEDURE AND SET-UP

The purpose of this menu screen is to set-up the Generator to start at a preset time on the second.

To use the External Start feature of this unit one must use the following procedure:

- a. Connect a 1PPS, TTL level, signal to rear panel BNC connector J6.
- b. Stop the Generator as described in Paragraph 3.7.1 of this Users Guide.

- c. Preset the Generator to the desired start time as described in Paragraph 3.7.8 of this User’s Guide.
- d. Using the External Start Setup Menu, Figure 3.7.11.1, select the Starting Edge desired.
- e. ARM the External Start one (1) Second prior to the entered start time.
- f. On the next selected edge of the External Start input signal the Generator will start.

The LCD Display will be as shown in Figure 3.7.11.1.

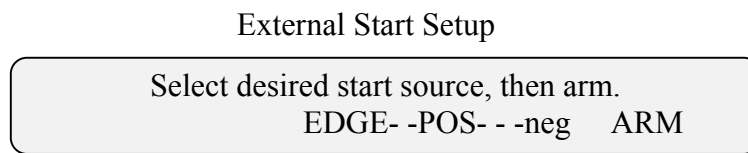

Figure 3.7.11.1

This menu is used when the external start input is a pulse. The start source should be connected to rear panel BNC J6. Selection of the Edge of the start pulse to be used to start the TM7000 is accomplished by using a switch located below the desired edge to be used, either Pos or Neg. The selected edge will be displayed on the LCD Display in uppercase letters.

Pressing the switch under ARM will cause a decimal point on the TENS of HOURS LED on the LED Time-of-Year Display to illuminate indicating the unit is armed. It will then start the Generator on the selected edge of the next input pulse (i.e. 1PPS etc.)

3.7.12 SETTING GENERATOR OUTPUTS

Selecting “OUTPUTS” from the Generator Setup Menu, Figure 3.7.12.1 changes the LCD Display to the Select Generator Output Menu, Figure 3.7.12.2

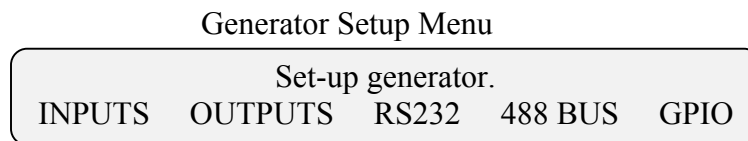

Figure 3.7.12.1

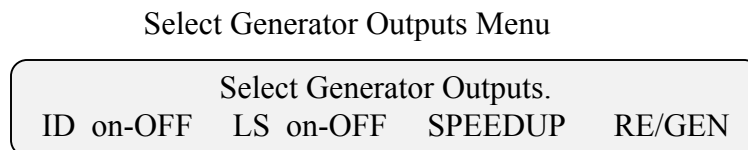

Figure 3.7.12.2

3.7.13 SELECTING ID (OR DAYS)

The Generator Outputs Menu, Figure 3.7.12.2, permits selection of the ID mode for the Generator. This selection allows the user to utilize the Days portion of the display, and in the Code Output, as a three digit ID (Identification Number). When ID has been set to ON, on will be in upper case letters and off will be in lower case letters. With ID “ON”, days are not updated at midnight rollover. Normally ID is OFF.

To enter an ID Number, use Inputting Time as described in paragraph 3.7.8 to enter the desired ID Number in the Days portion.

3.7.14 SELECTING LS (LEAP SECONDS)

The Select Generator Outputs Menu provides a method of setting Leap Seconds as either ON or OFF. Setting Leap Second (LS) “ON” any time within 24 hours prior to midnight will automatically add 1 Second to the Day, at midnight, and will then set itself to “OFF”

“ON” or “OFF” being in upper case letters designates the current mode selection of the function.

3.7.15 SELECTING GENERATOR SPEED-UP (MULTI-CODE SERIAL ENCODER)

Selecting “SPEEDUP” from the Select Generator Outputs Menu, Figure 3.7.12.2, will allow the generator speed-up rate to be selected as shown in Figure 3.7.15.1 below:

Select Generator Speed-Up Menu						
Select	Desired	Generator	Speed	up		
X1	X2	X4	X8	X16	X32	X64

Figure 3.7.15.1

The SPEED UP menu relates to the generator only. When sped up, most generator functions are inhibited (including the parallel outputs, video time insertion and J10 & J11 serial code output). START, STOP and time PRESET are preserved. If the unit is switched to Translate while the Generator is sped up, the Generator speed is automatically switched to 1:1 (real time). The allowable generator speed up is dependent on the time code being generated. IRIG G will function up to a 4:1 increase, while all other codes will work properly from 1:1 up to 32:1. The 32:1 speed is about one percent fast. The generator speed must be manually returned to 1:1 in order for the re/generate function to work correctly. Merely switching to the Translate mode will not assure proper regenerate operation.

NOTE

Following a change in selected code output or speed up (greater than 1:1 only) up to 100 seconds of code time may be required before the outputs are stable. Switching to a 1:1 (real time) speed will produce correct outputs immediately.

3.7.16 SELECTING GENERATOR RE/GEN (MULTI-CODE SERIAL ENCODER)

The RE/GENERATE menu (on the SELECT GENERATOR OUTPUTS menu) is used to select the output code for rear panel BNC connectors J12 (AC Code Output from Multicode) and J4 (DC Code Output from Multicode), regardless of whether the time source for the code is the generator or the translator. This Multi-code Serial Encoder is an integral part of the basic TM7000. This encoder generates IRIG A, IRIG B, IRIG G, NASA 36, XR3, 2137 or AN/GSQ-53 (250 Hz) as selected by the Output Code Menu as shown in Figure 3.7.16.1. Codes may be “re/generated” from the translator at multiple speeds.

Output Code Menu

Select Desired Channel N Output Code IRIG A--B--G NASA 36 XR3 2137 ANG

Figure 3.7.16.1

NOTE

- a. “N” is the current Encoder channel number. Advance with the NEXT button.
- b. Select the desired output code with a button directly under the menu item.

The TM7000 has a Multi-code Serial Encoder incorporated into the basic STCG. It’s channel number is fixed at “1”. The channel number is like an address. If an additional, optional, Multi-code Serial Encoder is installed in the option area, its channel number is selectable using DIP switches on the card. Its channel (address) number can be accessed from the above menu using the NEXT button under the LCD display. Only installed channel numbers are displayed. Multiple encoders may be assigned the same channel number during installation, or each encoder may be assigned a different channel number. Channels are numbered in “hex” from 1 to C. All other numbers are illegal. Set-ups are stored and remembered through power outages.

The term ‘re/generation’ refers to generating a time code output with the same time information as an input time code to the Translator. Output code selection is performed as described above. Input code selection is performed using the normal Translator controls. For re/generation to function correctly, the TM7000 must know the speed of the input and the output. This is accomplished using the FILTER menus to select ENVELOPE FILTER IN and PLAY SPEED RATIO to the rate of the input and output. When the input code is changed, these selections must be made again.

Any available output may be re/generated from any translated code with a (real time) frame period of one second or less. The allowable speed range is 1:1 through 64:1 for all input codes except IRIG G, which has a maximum rate of 2:1, and IRIG A which has a maximum rate of 16:1.

Note: When using the Multi-Encoder as a re/generator, the Translator must be set up for code and speed (if not 1:1) before the multi-encoder output code is selected.

CHAPTER THREE

The Multi-Code Serial Encoder may get time information from either the Generator or Translator according to which mode has been selected, or may be forced by a jumper to output either translator time or generator time, regardless of the mode of the TM7000. See Paragraph 3.2.5 B. This assembly is shipped with a jumper installed from J20 1-2 to force Generator time.

3.7.17 RS-232 I/O OPERATION/CONFIGURATION

Back on the Generator Set-Up Menu, Figure 3.7.17.2, selecting the “RS-232” mode of operation will lead to the LCD Display showing the BAUD Rate Selection, Figure 3.7.17.1.

Note: The factory default selection of the RS-232 I/O is 9600 BAUD, 8 bit word length, no parity, and 1 stop bit.

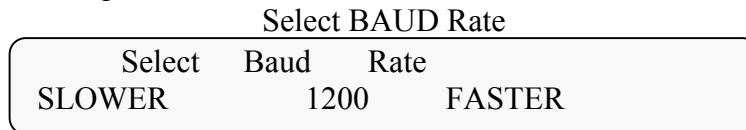

Figure 3.7.17.1

Pressing a switch under either “SLOWER” or “FASTER” will increase or decrease the BAUD rate from that currently displayed. Available baud rates are 50, 75, 110, 134.5, 150, 300, 600, 1200, 1800, 2400, 3600, 4800, 7200, 9600, 19200, and 38400. The receiver and transmitter are always set to the same baud rate.

Pressing the PREV switch will return the LCD Display to the Generator Set-Up Menu as shown below:

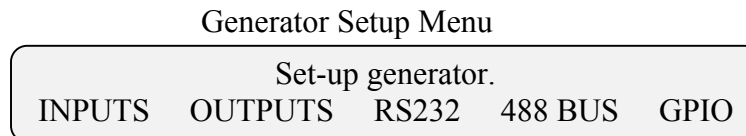

Figure 3.7.17.2

Pressing the NEXT switch will allow the user to select parity and stop bits.

Parity can be turned off or set to either even or odd. Either one or two stop bits can be selected.

Parity disabled and one stop bit:

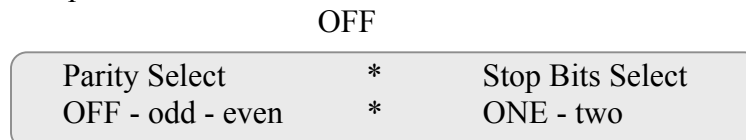

Figure 3.7.17.3

Select odd parity with one stop bit:

ODD		
Parity Select	*	Stop Bits Select
off - ODD - even	*	ONE - two

Figure 3.7.17.4

Select even parity with one stop bit:

EVEN		
Parity Select	*	Stop Bits Select
off - odd - EVEN	*	ONE - two

Figure 3.7.17.5

Select no parity with two stop bits:

TWO		
Parity Select	*	Stop Bits
OFF - odd - even	*	one - TWO

Figure 3.7.17.6

Pressing the NEXT switch will allow the user to select the word length and the output format.

One of two possible output formats can be selected. Either ASCII or PACKED-BCD. The character length is always eight bits if PACKED-BCD output format is selected, while either seven bit or eight bit character length may be selected if the ASCII output format is used. Naturally, the input character length is always the same as the output character length.

Select a word length of seven and the ASCII word output format:

SEVEN		
Word Length	*	Word Output Format
SEVEN eight	*	ASCII packed-bcd

Figure 3.7.17.7

Select packed BCD format: (Eight word length is automatic)

EIGHT		
Word Length	*	Word Output Format
seven EIGHT	*	ascii PACKED-BCD

Figure 3.7.17.8

For a description of the RS-232 interface commands and word output format tables, see Section 3.10, RS-232 Interface Data Input/Output.

3.8 TRANSLATOR OPERATION

The following paragraphs provide information on the Set-up and operation of the TM7000 in the Translator mode.

The Translate functions, Code, Filters, Direction and Polarity are stored in Memory and will remain there until changed or upon initiating a TM7000 Reset.

Translator operation and set-up is selected from the Select Versatile Display Function Menu screen shown in Figure 3.8.1

When Translator is selected from the Versatile Display Function Menu the Warning Message as shown in Figure 3.8.2 will appear on the LCD Display.



Figure 3.8.1

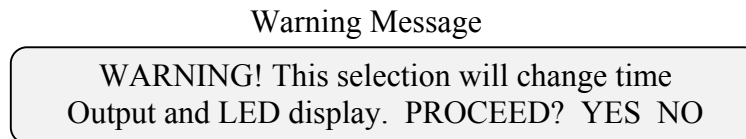

Figure 3.8.2

The unit will only proceed to a different mode if YES is selected from this menu. If NO is selected, the unit will revert to the previous menu and the mode remains intact.

Selecting YES from the Warning Message screen will change the LCD Display to the Set-Up Translator Menu shown in Figure 3.8.3

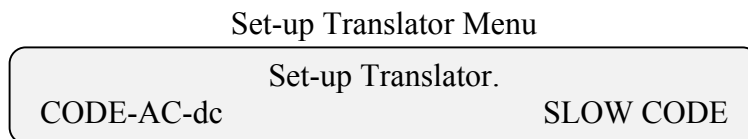

Figure 3.8.3

Frequently there will be no reason to proceed beyond this menu as the LED Display shows translated time, and all outputs are available as previously set-up.

When the Translator is initially powered up, it may be necessary to select the Serial Time Code being input to the Translator at BNC connector J8 on the rear panel of the unit. To select the desired input code press the NEXT switch which will change the LCD Display to the Select Desired Code Family Menu screen as shown in Figure 3.8.1.1.

The functions after CODE, AC-dc, select whether the input code is Amplitude Modulated (AC) or DC Level Shift (DC). If the Read DC Code option, TM Option 17, is not installed, selecting DC will not change the function, and the warning message shown in Figure 3.4.1 will be displayed. If TM Option 17 is installed see TM Option 17, Read DC Code Option Description, located in Appendix A.

The SLOW CODE selection requires that the Slow Code Assembly, TM Option 18, be installed. If the option is installed see TM Option 18 Option Description, located in Appendix A.

3.8.1 TRANSLATOR CODE INPUT SELECTION

The following menus and descriptions are used to allow the user to select type of Serial Time Code being input to the Translator.

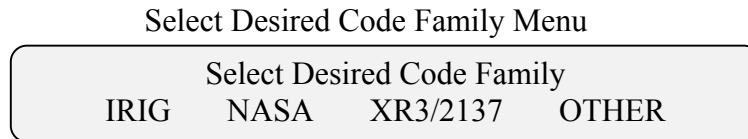

Figure 3.8.1.1

Selecting IRIG, by pressing the switch below IRIG, leads to the Select Desired IRIG Code Menu as shown in Figure 3.8.2.1, on the LCD Display, allowing the user to select any of the IRIG Serial Time Codes shown to be translated. Selecting NASA changes the LCD Display to the Select Desired NASA Code Menu, Figure 3.8.3.1 and selecting XR3/2137 causes the Select Desired Code Menu, Figure 3.8.4.1 to be displayed on the LCD Display screen.

3.8.2 TRANSLATOR IRIG CODE INPUT SELECTION

The Select Desired IRIG Code Menu allows the user to select the Desired IRIG Serial Time Code to be translated by the Translator.

Pressing the PREV switch while this menu is shown on the LCD Display will return it to the Set-Up Translator Menu, Figure 3.8.3.

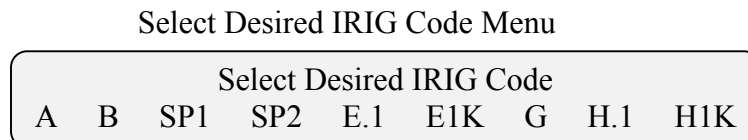

Figure 3.8.2.1

CHAPTER THREE

A blinking cursor appears at the presently selected IRIG code to be translated. The “.1” indicates a 100Hz code and the “1K” indicates a 1KHz code. If the desired code has been selected, pressing the NEXT switch will cause the Translating Menu, Figure 3.8.5.1 to be displayed on the LCD Display.

If there is not a blinking cursor on this menu no IRIG code has been selected. If it is desired to see what input code has been selected press the NEXT switch and the Translating Menu, Figure 3.8.5.1, will appear on the LCD Display showing the selected Translator code selected in the upper right hand corner after “Translating”.

If the input code is different than that shown on the display, it is necessary to select the correct code. Changing the code selection is accomplished by pressing the switch beneath the desired code. When the new desired code is selected the LCD Display will change to that shown in Figure 3.8.5.1 with the selected code being translated shown in the upper right hand corner of the display.

The selection of SP1 or SP2 are reserved for translation of special codes, and the message “Selected option is not installed...(See Figure 3.4.1) will appear. If either one of these special codes are provided, its option description will be in Appendix A.

3.8.3 TRANSLATOR NASA CODE INPUT SELECTION

The Select Desired NASA Code Menu, Figure 3.8.2.1, is used to select the NASA code to be translated. If the code has previously been selected, skip to the Translating Menu, Figure 3.8.5.1 by pressing NEXT. To select a code, push the corresponding switch. Pressing the PREV switch while the Translating Menu is shown on the LCD Display will return it to the Set-Up Translator Menu, Figure 3.8.3.



Figure 3.8.3.1

A blinking cursor will appear on the selected code to be translated. If the desired code has been selected, pressing the NEXT switch will cause the Translating Menu, Figure 3.8.5.1 to be displayed on the LCD Display.

If no blinking cursor appears on this menu, none of the NASA codes have been selected. Pressing the NEXT switch causes the Translating Menu Figure 3.8.5.1 to appear on the LCD Display showing the selected Translator Code in the upper right hand corner after “Translating”.

Should the input code be different than that previously selected, it is necessary to select the correct code. Selecting the correct code is accomplished by pressing the switch beneath the desired code. When the new code selection is made, the LCD Display will change to that shown in Figure 3.8.5.1 with the selected code being translated shown in the upper right hand corner of the display.

Selection of 28.1 corresponds to NASA 28 with a carrier frequency of 100 Hz. Selection of 28K corresponds to NASA 28 with a carrier frequency of 1KHz. If selected, the message “Selected option is not installed...(See Figure 3.4.1) will appear.

3.8.4 TRANSLATOR XR3/2137 CODE INPUT SELECTION

The Select Desired XR3/2137 Code Menu, Figure 3.8.4.1, is used to select a code which is a member of the XR3 family to be translated. If the desired code has previously been selected, skip to the Translating Menu, Figure 3.8.5.1 by pressing NEXT.

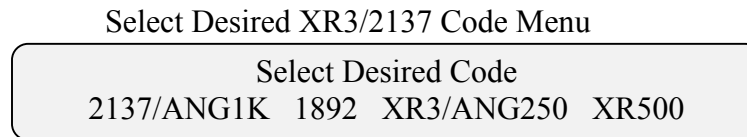

Figure 3.8.4.1

To select a code from this group, push the corresponding switch below the displayed code. Upon selection of a new code, the LCD Display will change to that shown in Figure 3.8.5.1 with the selected code being translated shown in the upper right hand corner of the display.

Pressing the PREV switch while this translating menu is shown on the LCD Display will return it to the Select Desired Code Family Menu, Figure 3.8.1.1.

3.8.5 TRANSLATING MENU

This menu is normally displayed while translating. It shows the code being translated and the Filter, Direction, and Polarity selected.

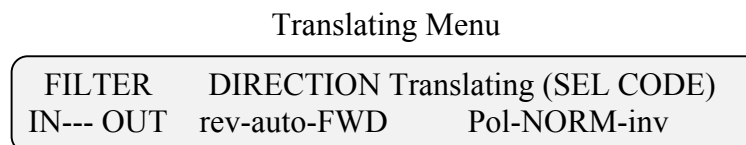

Figure 3.8.5.1

When any switch under FILTER “IN --- OUT” is selected from the Translating Menu, the LCD Display changes to the Select Filters Menu screen Figure 3.8.6.1.

When a switch is pressed below rev, auto or fwd under “DIRECTION” the direction is selected. The selected DIRECTION will be displayed in upper case letters. When REV is selected the Translator is forced into Reverse. When AUTO is selected, Auto Forward/Reverse detection is enabled. When FWD is selected, the Translator is forced into Forward. Translating is most robust when “AUTO” is not used.

Pressing the switch below norm or inv after Pol selects the Polarity of the incoming code. The selected Polarity will be displayed in upper case letters. NORM selects Normal Polarity and INV selects Inverted Polarity.

CHAPTER THREE

If the code into the TM7000 has normal Polarity, “NORM” should be selected. If the input code is inverted, “INV” should be selected. When the direction of the input code is reversed, a Polarity inversion takes place automatically to provide optimal translating capability.

The update rate of translated time on the LED Display is changed according to the code being translated, and the rate (real time versus speed-up). This can cause a peculiar appearance of the time display. If, for example, the seconds update ten times as fast as the display, they would not appear to change. Changing the code speed slightly could cause the seconds display to increment (or even decrement) at a slow rate. This phenomenon only occurs at rates much faster than real time.

Pressing NEXT or PREV will change the LCD Display to the Warning Message screen, Figure 3.8.2, which forces the user to make a decision on whether to proceed or not to proceed. Making the decision to Proceed “YES” returns the LCD Display to the Select Versatile Display Function Menu, Figure 3.8.1 allowing the user to select the TM7000 operating mode in which to operate.

3.8.6 FILTERS

The Select Filters LCD Display as shown in Figure 3.8.6.1, provides for the enabling and disabling of independent filters for the Envelope and Carrier of the input code.

When the “IN” below CARRIER FILTER is selected “IN” will be displayed in upper case letters and “out “ will be displayed lower case letters.

The Carrier Filter is a band pass filter, implemented with a Phase Lock Tracking filter, designed to remove extra, and/or supply missing carrier cycles.

The “COAST” switch enables/disables freewheeling during dropouts or loss (below the threshold set by R132) of input code. If the carrier frequency is not precise (within 1%), disable the carrier filter.

The Carrier Filter must be IN (enabled) for the “COAST” function to operate.

When “COAST” is displayed in upper case letters it is enabled. If “coast” is in lower case letters it is disabled.

Note: When reading codes with more than one second between elements, adjust the threshold for “space” cycles or enable “COAST” to prevent discontinuous translation.

Select Filters Display



Figure 3.8.6.1

The Envelope Filter is a two pole low pass filter designed to improve performance by removing higher frequencies from the input code.

When “IN” under ENVELOPE FILTER is selected, it will be in upper case letters and “out” will be in lower case letters. When IN, Filters appropriate to the real-time rate of the code are enabled. The appropriate filter for the code selected is preset when the input code was selected. If only the envelope filter is enabled, the filter frequency may be set higher than the input rate, but this must never be done when the carrier filter is enabled. To accommodate uncontrolled tape search speeds, the search filters may be selected OUT, or higher than the fastest speed selected.

When NEXT is pressed while the Select Filters Display is shown on the LCD Display it will change to the Play/Search Speed Menu as shown in Figure 3.8.6.2. Note that either (or both) the Envelope Filter or the Carrier Filter have to be selected IN.

Play/Search Speed Menu

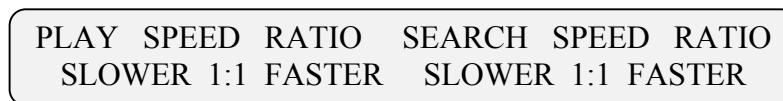

Figure 3.8.6.2

This menu provides for selecting the frequency of the filters during Playback operation and (optionally) Search operation. Filters are selected as a multiple of the real-time rate, in accordance with the previously selected code. If only the Envelope Filter is enabled, the filter frequency may be set higher than the input rate, but this must never be done when the Carrier Filter is enabled. To accommodate uncontrolled Tape Search speeds, the Search Filters may be selected OFF by going “faster” than the maximum rate.

The filters are selectable from nominal rates of 31.25Hz to 400KHz depending on the selected code. The actual corner frequency of the Envelope Filters is approximately one and a half times nominal, i.e. 1.5KHz for IRIG B at 1:1.

The PLAY SPEED RATIO and the SEARCH SPEED RATIO may be set slower by pressing any switch under SLOWER, or set faster by pressing any switch below FASTER.

The PLAY SPEED RATIO and the SEARCH SPEED RATIO selected is displayed on the LCD Display between SLOWER and FASTER for each.

CHAPTER THREE

For Tape Search operation see TM Option Description, TM 02/02A, which is located in Appendix A.

3.9 EXTERNAL FREQUENCY INPUT OPERATION

An External Frequency (External Oscillator), any integer of 1 through 10 MHz (1, 2, 3 MHz, etc.) can be input to the TM7000 at rear panel BNC connector J5, and may be used to operate the TM7000 in lieu of the internal oscillator. This input must be TTL Square Wave or Sine Wave with a minimum amplitude of 1 volt Peak-to-Peak and a maximum of 5 volts Peak-to-Peak into a 50 Ohm load.

When an External Frequency (External Oscillator) is input to the TM7000 via J5, the External Frequency input is automatically used. When it is removed, the Internal Oscillator is automatically selected for use. In order for this feature to operate, an internal jumper (J22) must be selected as shown below:

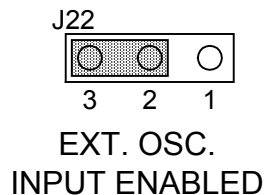

Note: This rear panel BNC is also used for 10MHz Sine Wave Output Operation (See Section 3.10), so it is important that the above jumper be selected for the desired feature. External Oscillator Input Enabled is the factory default setting for this jumper.

3.10 10MHZ SINE WAVE OUTPUT

On rear panel BNC connector J5, the TM7000 can generate a 10MHz sine wave. This sine wave is derived and buffered from the internal oscillator (whichever is installed). In order for this feature to operate, an internal jumper (J22) must be selected as shown below:

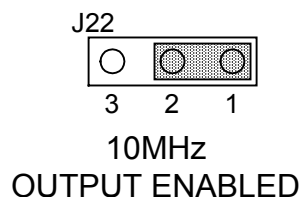

Note: This rear panel BNC is also used for External Frequency Input Operation (See Section 3.9), so it is important that the above jumper be selected for the desired feature.

The level (amplitude) of the 10MHz output can be adjusted using potentiometer R184. See Figure 2.2 in Chapter Two.

3.11 RS-232 INPUT/OUTPUT(I/O)

3.11.1 INTRODUCTION

This function is designed in accordance with EIA RS-232 specifications and provides the electrical interface between the TM7000 TGG/T and a RS-232 serial interface.

In this section, all the RS-232 commands are listed. However, the assemblies that they are addressing may be optional.

Connection to the RS-232 interface is via the rear panel 9-pin "D" connector (J2). Input data to this interface is accepted through TXD and output data from this interface is transmitted through RXD. Please refer to Chapter One for the pin assignments.

For Menu operation and the selection of BAUD rate, parity, number of stop bits, word length and output format, see Section 3.7.17 (this Chapter).

***** CAUTION *****

When using this RS-232 I/O for set up control, the local (front panel LCD and switch) controls should not be used simultaneously to set up the same function. This could lead to erroneous or incompatible commands. It should also be noted that after having used the RS-232 I/O for set up control, this configuration can be overwritten by the local controls

Note: The handshake lines DTR, DSR, RTS AND CTS are used in this assembly. If not required by the user, DTR and RTS (both options) must be pulled up through a jumper to pin 11 in the connector.

Terms followed by “/” designate active Low signals.

***** WARNING *****

If the handshake lines are not used, then it may be necessary for the user to program a delay of up to 10 milliseconds between consecutive characters sent from the computer to the TM7000 to allow sufficient time to process each character before the next one is received.

One of two possible output formats can be selected, either ASCII or PACKED-BCD. The character length is always eight bits if PACKED-BCD output format is selected, while either seven bit or eight bit character length may be selected if the ASCII output format is used. The input character length is always the same as the output character length.

CHAPTER THREE

A. PACKED BCD FORMAT:

Outputs a string of eight bit characters, each of which contains two BCD digits. Normal ASCII control characters cannot be used with this format, since data values can take on the image of control characters.

B. ASCII FORMAT:

Outputs a string of ASCII numeric characters, each character representing one digit of the time message.

3.11.2 PROGRAMMING

If the handshake lines (DTE/DTR and RTS/CTS) are used, then any baud rate up to the maximum 38400 can be used without concern. However, if these handshake lines are not used, then a delay of up to 10 milliseconds may be required between the end of one character and the beginning of the next character in the command string being input to the TM7000. This time delay ensures that the command decoder has serviced the previous character and is ready for the next one.

A command string to the TM7000 is a string of six ASCII characters, which always begins with two "slash" characters (/). The sixth character is often followed by a data character, as in the case of setting the time of the generator.

3.11.3 TO ENTER SETUP AND CONTROL DATA

- a. The computer (DTE) initiates the handshake by asserting DTR. The TM7000 responds by asserting DSR.
- b. The computer then asserts RTS. The TM7000 responds by asserting CTS.
- c. The computer outputs the first character of the command string.
- d. When the character is received, the TM7000 removes CTS until the character has been processed. When the TM7000 is ready for the next character, it will assert CTS.
- e. Steps "c" and "d" are repeated as often as is necessary to transmit a complete command (plus a data character when appropriate).
- f. After all command characters have been transferred, the computer may remove both RTS and DTR until a new command is to be sent. Alternatively, the computer may remove RTS, but continue to assert DTR in anticipation of a later command transmission.

3.11.4 TO REQUEST OUTPUT OF TIME & STATUS MESSAGES

- a. The computer (DTE) initiates the handshake by asserting DTR. The TM7000 responds by asserting DSR.
- b. The computer then asserts RTS. The TM7000 responds by asserting CTS.
- c. The computer outputs the first character of the command string.
- d. After the character is received, the TM7000 removes CTS until the character has been processed. When the TM7000 is ready for the next character, it will assert CTS.
- e. Steps “c” and “d” are repeated until a complete command has been transferred.
- f. The TM7000 continues to assert CTS and outputs the required response (from one to 15 characters).
- g. After all time or status characters have been transferred, the computer may remove both RTS and DTR until a new command is to be sent. Alternatively, the computer may remove RTS, but continue to assert DTR in anticipation of a later command transmission.

Note: If RTS is removed by the computer prior to completion of a time or status output message, the TM7000 will finish the current character (if one is in progress) and then pause until RTS is asserted again, at which time the output message will be completed. If DTR is removed prior to completion of a time or status output message, the TM7000 will finish the current character (if one is in progress) and then abort the output process.

Note: Although inputs can be accepted by the TM7000 while it is outputting data, a time or status command will not be processed while a time or status output is in progress. As a general rule, it is best to consider this channel to be “half-duplex” which means that traffic should be processed in only one direction at any given time.

3.11.5 PROGRAMMING THE GENERATOR

The command strings on the following pages are used to control the operation of the time code generator portion of the TM7000. The command interpreter is "case insensitive" for the ASCII letters. For purposes of clarity, the letter "L" is always shown in upper case to differentiate it from the digit "1," while the letter "o" is always shown in lower case to differentiate it from the digit "0." All other alphabet characters are shown in lower case. Subscripted letters (e.g., D_H) represent a single ASCII numeric character. This example (D_H) represents the "hundreds of days" digit.

A. SELECT DISPLAY/DATA MODE

//L200	Select Translate Mode
//k100	Select Generate Mode
//k101	Synchronized Time Code Generator ENABLED
//k102	Synchronized Time Code Generator DISABLED

B. SLOW CODE FRAME PERIOD SELECTION

//k000	1 Second
//k004	5 Seconds
//k008	10 Seconds
//k010	60 Seconds
//k018	600 Seconds

C. SET TIME CODE GENERATOR TIME

//kk00	Stop the Generator
//kk99	Start the Generator
//k70Y _L	Set Leap Year (Y _L is 0, 1, 2, or 3. 0=Leap Year)
//k60D _H	Set Hundreds of Days digit (D _H =0-9)
//k5D _T D _U	Set Tens and Units of Days digits (D _T =0-9, D _U =0-9)
//k4H _T H _U	Set Tens and Units of Hours digits (H _T =0-2, H _U =0-9)
//k3M _T M _U	Set Tens and Units of Minutes digits (M _T =0-5, M _U =0-9)
//k2S _T S _U	Set Tens and Units of Seconds digits (S _T =0-5, S _U =0-9)
//kL00	Use Positive Edge of External Start input signal
//kL08	Use Negative Edge of External Start input signal
//km40	Arm External Start (Stop the TCG before arming)

D. SET PROPAGATION DELAY COMPENSATION

//kjS _{.1} S _{.01}	Set .1 Sec and .01 Sec
//kiS _{.001} S _{.0001}	Set .001 Sec and .0001 Sec
//khS _{.00001} S _{.000001}	Set .00001 Sec and .000001 Sec

E. SELECT MULTICODE OUTPUT(S)

//mX00 Generate IRIG B
 //mX06 Generate IRIG A
 //mX0L Generate IRIG G
 //mX3L Generate 2137
 //mX42 Generate NASA 36
 //mX5j Generate XR3-250
 //mX6p Generate ANGSQ53-250

Note: X equals the channel (encoder) number. The basic (STCG) is number 1. Optional plug-ins can be any number from 1-7.

3.11.6 PROGRAMMING THE TRANSLATOR**A. TAPE PLAYBACK SPEED RATIO**

<u>Playback</u>	<u>Search Playback:Record Ratio</u>
//L000 //L100	1:128 Slow Playback
//L001 //L101	1:64 Slow Playback
//L002 //L102	1:32 Slow Playback
//L003 //L103	1:16 Slow Playback
//L004 //L104	1:8 Slow Playback
//L005 //L105	1:4 Slow Playback
//L006 //L106	1:2 Slow Playback
//L007 //L107	1:1 Realtime Playback
//L008 //L108	2:1 Fast Playback
//L009 //L109	4:1 Fast Playback
//L00j //L10j	8:1 Fast Playback
//L00k //L10k	16:1 Fast Playback
//L00L //L10L	32:1 Fast Playback
//L00m//L10m	64:1 Fast Playback
//L00n //L10n	128:1 Fast Playback
//L00o //L10o	256:1 Fast Playback

B. TRANSLATOR FUNCTION CONTROLS

//L300 Translate IRIG B
//L306 Translate IRIG A
//L30L Translate IRIG G
//L312 Translate IRIG E - 100
//L318 Translate IRIG E - 1K
//L31n Translate IRIG H - 100
//L324 Translate IRIG H - 1K
//L32j Translate IRIG C - 100
//L330 Translate IRIG C - 1K
//L33L Translate 2137/ANGSQ53 – 1K
//L342 Translate NASA 36
//L34n Translate NASA 28 - 100
//L354 Translate 1892
//L35j Translate XR3/ANGSQ53-250
//L700 Normal Code Polarity
//L799 Inverted Code Polarity
//L800 Select AC Code translate
//L840 Select DC Code Translate
//L220 Select forward direction
//L201 Select reverse direction
//L221 Select Auto direction

//kL41 (Carrier filter on, Envelope filter off)
//kL81 (Envelope filter on, carrier filter off)
//kLL1 (Both filters on)
//kL01 (Both filters off)

3.11.7 PROGRAMMING THE TAPE SEARCH CONTROL OPTION

The TM7000 can be programmed to automatically search for any number of Tape Search Intervals up to a maximum of ten. In the following command sequences, the letter “X” represents an ASCII number character in the range of 0 to 9, which is the number of the Tape Search Interval of interest. The subscripted letters each represent a single ASCII numeric character (e.g., D_H= hundred’s of days).

A. TAPE SEARCH TIME VALUES

<u>Start Time</u>	<u>Stop Time</u>	<u>Time Value</u>
//XnD	//X60D _H	Hundred of days
//XmD _T D _U	//X5C	Tens, units of days
//XLH _T H _U	//X4H _T H _U	Tens, units of hours
//XkM _T M _U	//X3M _T M _U	Tens, units of minutes
//XjS _T S _U	//X2S _T S _U	Tens, units of seconds
//X9S _{.1} S _{.01}	//X1S _{.1} S _{.01}	0.1 second, 0.01 second
//X8S _{.001} 0	//X0S _{.001} 0	0.001 second

B. SELECT PROGRAMMED TAPE SEARCH INTERVAL

//jL0X Select Last Interval (first interval is always interval 0)
 //jm0X Select specific single interval

C. SELECT TAPE TRANSPORT DELAY

//j301 1 Second
 //j302 2 Seconds
 //j304 4 Seconds
 //j308 8 Seconds
 //j30L 12 Seconds
 //j310 16 Seconds
 //j312 18 Seconds
 //j314 20 Seconds

D. EARLY CLOSURE DELAY SELECTION

//j500 0 Delay
 //j501 1 Second
 //j502 2 Seconds
 //j503 3 Seconds
 //j506 6 Seconds
 //j508 8 Seconds
 //j50j 10 Seconds
 //j510 16 Seconds

E. TAPE SPEED SELECTION

//j400 15/16 IPS
//j401 1 7/8 IPS
//j402 3 3/4 IPS
//j403 7 IPS
//j404 15 IPS
//j405 30 IPS
//j406 60 IPS
//j407 120 IPS
//j408 240 IPS

F. AUTOMATIC TAPE SEARCH MODE CONTROL

//j600 Search to Start Mode
//j602 Single Cycle - Single Interval Mode
//j604 Single Cycle - Multiple Interval Mode
//j607 Auto Record
//j609 Recycle Mode
//j60j Start Search
//j60L Stop

G. MANUAL SEARCH TAPE MOTION CONTROL

//j700 Forward
//j701 Fast Forward
//j702 Reverse
//j703 Fast Reverse
//j704 Stop
//j705 Record

Note: To record, first send Record [//j705] command followed by the appropriate direction [//j700 or //j702] command.

H. TRANSPORT CONTROL PARAMETERS

//jk00 Motion Control = Continuous;
 Motion (e.g., Fast) First; Speed = Continuous

//jk10 Motion Control = Continuous;
 Motion First; Speed = Momentary

//jk20 Motion Control = Continuous;
 Direction (e.g., Fwd) First; Speed = Continuous

//jk30 Motion Control = Continuous;
 Direction First; Speed = Momentary

//jk40 Motion Control = Momentary;
 Motion First; Speed = Continuous

//jk50 Motion Control = Momentary;
 Motion First; Speed = Momentary

//jk60 Motion Control = Momentary;
 Direction First; Speed = Continuous

//jk70 Motion Control = Momentary;
 Direction First; Speed = Momentary

3.11.8 PROGRAMMING TIME OUTPUT REQUESTS**A. TIME OUTPUT REQUEST**

//komn Generator Time Word Output
 //komo Translator Time Word Output

Time is output as either a string of ASCII characters or as Packed-BCD characters. Please see Figures One and Two for the output format definitions.

3.11.9 PROGRAMMING STATUS OUTPUT REQUESTS

Each status request returns a single 8-bit character (byte). In order to use this feature, the TM7000 Series must be set up for 8-bit characters (not 7-bit characters), since the status byte requires 8 bits. The numeric status is in a packed-BCD format, which means that each four bits of a byte contain one BCD digit.

CHAPTER THREE

A. GENERATOR TIME VALUES

<u>Command</u>	<u>Status Response</u>
//ko5n 0	D _H (Hundreds of Days)
//ko5m D _T	D _U (Tens & Units of Days)
//ko5L H _T	H _U (Tens & Units of Hours)
//ko5k M _T	M _U (Tens & Units of Minutes)
//ko5j S _T	S _U (Tens & Units of Seconds)
//ko59 S _{.1}	S _{.01} (tenths & hundredths of Seconds)
//ko58 S _{.001}	S _{.0001} (milliseconds & tenths of milliseconds)

B. PROPAGATION DELAY COMPENSATION

<u>Command</u>	<u>Status Response</u>
//ko02 0.1 Sec	0.01 Sec
//ko01 0.001 Sec	0.0001 Sec
//ko00 0.00001 Sec	0.000001 Sec

C. REQUEST MULTICODE STATUS

//nX00 00	Generate IRIG B
//nX00 06	Generate IRIG A
//nX00 0<	Generate IRIG G
//nX00 3<	Generate 2137
//nX00 42	Generate NASA 36
//nX00 5:	Generate XR3-250
//nX00 60	Generate ANGSQ53-250

Note: X equals the channel (encoder) number. The basic (STCG) is number 1. Optional plug-ins can be any number from 1-7.

D. TRANSLATOR TIME VALUES

<u>Command</u>	<u>Status Response</u>
//ko86 0	D _H
//ko85 D _T	D _U
//ko84 H _T	H _U
//ko83 M _T	M _U
//ko82 S _T	S _U
//ko81 S _{.1}	S _{.01}
//ko80 S _{.001}	0

E. TRANSLATOR CONTROL SETTINGS

<u>Command</u>	<u>Status Response</u>
//ko8o 00	(Translating IRIG B)
//ko8o 06	(Translating IRIG A)
//ko8o 0L	(Translating IRIG G)
//ko8o 12	(Translating IRIG E - 100)
//ko8o 18	(Translating IRIG E - 1K)
//ko8o 1n	(Translating IRIG H - 100)
//ko8o 24	(Translating IRIG H - 1K)
//ko8o 2j	(Translating IRIG C - 100)
//ko8o 30	(Translating IRIG C - 1K)
//ko8o 3L	(Translating 2137 or GSQ53-1K)
//ko8o 42	(Translating NASA 36)
//ko8o 4n	(Translating NASA 28)
//ko8o 54	(Translating 1892)
//ko8o 5j	(Translating XR3 or GSQ53-250)
//kok7 00	(Normal Code Polarity)
//kok7 99	(Inverted Code Polarity)
//L500 01	(Forward direction)
//L500 20	(Reverse direction)
//L500 21	(Auto direction)
//kL02 0	Both filters on
//KL02 4	Envelope filter on
//kL02 8	Carrier filter on
//kL02 <	Both filters off

F. TAPE SEARCH START TIME/STOP TIME VALUES

The X digit is an ASCII numeric in the range of 0-9 indicating the interval number to be interrogated.

<u>Command</u>	<u>Status Response</u>
//LoXn0	D _H (Start Time, Hundreds of Days)
//LoXm	D _T D _U (Start Time, Tens & Units of Days)
//LoXL	H _T H _U (Start Time, Tens & Units of Hours)
//LoXkM _T	M _U (Start Time, Tens & Units of Minutes)
//LoXj S _T	S _U (Start Time, Tens & Units of Seconds)
//LoX9 S _{.1}	S _{.01} (Start Time, tenths & hundredths of Seconds)
//LoX8 S _{.001}	0 (Start Time, milliseconds)
//LoX60	DH (Stop Time, Hundreds of Days)
//LoX5DT	DU (Stop Time, Tens & Units of Days)
//LoX4HT	HU (Stop Time, Tens & Units of Hours)
//LoX3MT	MU (Stop Time, Tens & Units of Minutes)
//LoX2ST	SU (Stop Time, Tens & Units of Seconds)
//LoX1 S _{.1}	S _{.01} (Stop Time, tenths & hundredths of Seconds)
//LoX0 S _{.001}	0 (Stop Time, milliseconds)

G. TAPE TRANSPORT CONTROLS (Response values are Hex)

<u>Command</u>	<u>Status Response</u>
//Loj3 01	(TTD=1 Second)
//Loj3 02	(TTD=2 Seconds)
//Loj3 04	(TTD=4 Seconds)
//Loj3 08	(TTD=8 Seconds)
//Loj3 0C	(TTD=12 Seconds)
//Loj3 10	(TTD=16 Seconds)
//Loj3 12	(TTD=18 Seconds)
//Loj3 14	(TTD=20 Seconds)
//Loj4 00	(Tape Speed=15/16 ips)
//Loj4 01	(Tape Speed=1 7/8 ips)
//Loj4 02	(Tape Speed=3 3/4 ips)
//Loj4 03	(Tape Speed=7 2 ips)
//Loj4 04	(Tape Speed=15 ips)
//Loj4 05	(Tape Speed=30 ips)
//Loj4 06	(Tape Speed=60 ips)
//Loj4 07	(Tape Speed=120 ips)
//Loj4 08	(Tape Speed=240 ips)
//Loj5 00	(ECD=0)
//Loj5 01	(ECD=1 Second)
//Loj5 02	(ECD=2 Seconds)
//Loj5 03	(ECD=3 Seconds)
//Loj5 06	(ECD=6 Seconds)
//Loj5 08	(ECD=8 Seconds)

//Loj5 0A (ECD=10 Seconds)
 //Loj5 10 (ECD=16 Seconds)

H. TAPE SEARCH STATUS

This byte is encoded with each bit indicating the status of a separate function

<u>Command</u>	<u>Status Response</u>
//Loj6 Bit 0	0=Tape Speed Fast (wind or rewind) 1=Tape Speed Normal
Bit 1	0=Inside the Search Interval 1=Outside the Search Interval
Bit 2	0=Early Interval (Start Time, Forward Playback mode) 1=Not Early Interval
Bit 3	0=Forward command is asserted 1=Forward command is not asserted
Bit 4	0=Reverse command is asserted 1=Reverse command is not asserted
Bit 5	0=Record command is asserted 1=Record command is not asserted
Bit 6	0=Stop command is asserted 1=Stop command is not asserted
Bit 7	Not Used

3.11.10 TIME WORD OUTPUT FORMATS (RS-232 I/O):

TABLE 3-1
Packed-BCD Format
Time Word Output

Bit Index	7	6	5	4	3	2	1	0
Byte #1	E R R	L O S	X	X	HD			
					8	4	2	1
#2	TD				UD			
	8	4	2	1	8	4	2	1
#3	0	0	TH		UH			
			2	1	8	4	2	1
#4	0	TM			UM			
		4	2	1	8	4	2	1
#5	0	TS			US			
		4	2	1	8	4	2	1
#6	tS				hS			
	8	4	2	1	8	4	2	1
#7	mS				0	0	0	0
	8	4	2	1				

Notes:

- a. Word #1 is output first.
- b. When Translator Time is output, ERR indicates an error in the input code and LOS indicates a low time code input amplitude.
- c. When Generator Time is output, ERR and LOS have no meaning.
- d. The bits marked “X” have no meaning, and should be ignored.

TABLE 3-2
ASCII Format
Time Word Output

Bit Index	7	6	5	4	3	2	1	0
Byte #1	Hundreds of Days							
#2	Tens of Days							
#3	Units of Days							
#4	Tens of Hours							
#5	Units of Hours							
#6	Tens of Minutes							
#7	Units of Minutes							
#8	Tens of Seconds							
#9	Units of Seconds							
#10	tenths of Seconds							
#11	hundredths of Seconds							
#12	milliseconds							
#13	0	0	0	0	E R R	L O S	X	X
#14	Carriage Return							
#15	Line Feed							

Notes:

- a. Word #1 is output first.
- b. When Translator time is output, ERR indicates an error in the input code and LOS indicates a low time code input amplitude.
- c. When Generator Time is output, ERR and LOS have no meaning.
- d. The bits marked "X" have no meaning and should be ignored.

CHAPTER THREE

3.12 RS-232 TIME WORD OUTPUT (TALKER)

3.12.1 INTRODUCTION

This output is designed in accordance with EIA RS-232C/RS-422 specification and is used to provide an electrical interface between any TM7000 timing instrument and the RS-232/RS-422 serial interface. This section provides the user with configuration information.

3.12.2 GENERAL DESCRIPTION

This talker output can be divided into two sections: Time extraction and RS-232/RS-422 communication. The RS-232/RS-422 communication portion will be the main focus of this section. The time extraction portion of this output is invisible to the user. The time is updated every millisecond unless the unit is sending a time message. It is suggested that the user read this section in its entirety for a better understanding of the options provided and what they mean.

3.12.3 TERMINAL TYPE

There are two basic configurations that need to be described before serial communication can be discussed: Data Communication Equipment (DCE) and Data Terminal Equipment (DTE). The major differences between the two configurations are their rules and pin assignments. DTE is designated as the initiator of the commands. DCE is designated as the responder to the commands. **This terminal (talker) is configured as DCE.** It is important to remember that most computer RS-232 communication ports are set up in the DTE configuration, which dictates that this unit be configured as DCE.

3.12.4 DCE HANDSHAKING

This talker is expecting at least two signals from the user's equipment: DTR and RTS. A third possibility would be TXD and it would only be used in the asynchronous mode. When the DTR signal is not active, the DSR and CTS signals will both be inactive and this unit will not send any time messages. When the DTR signal goes active, the DSR and CTS signals will both go active. A time message will be transmitted only when both DTR and RTS are both active. If RTS goes inactive while a time message output is in progress, the time message output will be paused until RTS returns to active, at which time the time message will resume. A partial message can be cleared by setting DTR inactive.

3.12.5 MODES OF OPERATION

There are two modes of operation possible with this talker: *Synchronous* (burst), and *asynchronous* (demand/response). The *synchronous* mode provides a time message at regular intervals selected by the user. The *asynchronous* mode outputs a time message upon receipt of a predefined character. The 8 bit image of the demand character is set by the user by means of an 8 bit DIP switch.

Note: The selection of Mode, Rate, BAUD Rate, Parity, Stop Bits, Format etc. are all made using DIP switches. The factory default for these switches is ASCII, 9600 BAUD, 8 Bits, no Parity, 1 Stop bit, and a message output (Rate) once every second. The operation of an individual switch is:

When a switch (in this example Switch 1) is set to the “ON” position, the voltage for that selected line is low, or 0 volts. This equates to a binary “0”.



When a switch (in this example Switch 1) is set to the “OFF” position, the voltage for that selected line is high, or +5 volts. This equates to a binary “1”.



A. SYNCHRONOUS MODE (Switch S4)

This unit is capable of providing time messages at five different rates:

- a. Ten messages per second.
- b. One message per second.
- c. One message per ten seconds.
- d. One message per one-hundred seconds.
- e. One message per 1000 seconds.

Note: Although the Mode is selected by Switch S4, the actual message rate is selected by Switch S1 as follows:

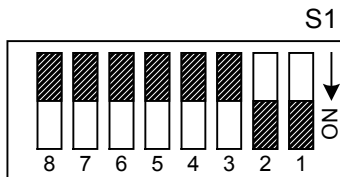

SW #1	SW #2	SW #3	MESSAGE RATE
ON (0)	ON (0)	ON (0)	10 TIMES PER SECOND
ON (0)	ON (0)	OFF (1)	ONCE PER SECOND
ON (0)	OFF (1)	ON (0)	ONCE EVERY 10 SECONDS
ON (0)	OFF (1)	OFF (1)	ONCE EVERY 100 SECONDS
OFF (1)	ON (0)	ON (0)	ONCE EVERY 1000 SECONDS
OFF (1)	ON (0)	OFF (1)	ONCE EVERY 1000 SECONDS
OFF (1)	OFF (1)	ON (0)	ONCE EVERY 1000 SECONDS
OFF (1)	OFF (1)	OFF (1)	ONCE EVERY 1000 SECONDS

In the example above, the message rate is once every second.

B. ASYNCHRONOUS MODE (Switch S4)

When this unit is set up in the asynchronous mode, the time output rates described in “Synchronous Mode” will be ignored. The user must select an 8 bit character (any hex value from 00 to FF) as a time demand character. The user sends the selected character to this unit, which causes a time message to be output in response.

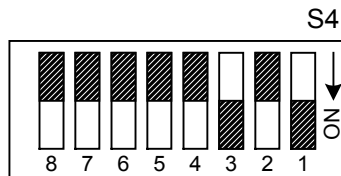

SW. #	SW. POSITION	DESCRIPTION
1	ON (0)	ASYNCHRONOUS
	OFF (1)	SYNCHRONOUS (DEFAULT)
2	ON (0)	7 BIT WORD
	OFF (1)	8 BIT WORD (DEFAULT)
3	ON (0)	FULL HANDSHAKE
	OFF (1)	NO HANDSHAKE (DEFAULT)
4	ON (0)	TEST
	OFF (1)	OPERATE (DEFAULT)

In the example above, the Mode is asynchronous, it is an 8 bit word, full handshake, and in the operate (default) mode.

3.12.6 MESSAGE FORMAT

The message format can be divided into several subdivisions:

- a. ASCII/BCD
- b. Baud Rate*
- c. Stop Bit*
- d. Parity*
- e. Word Length (ASCII only)
- f. Preamble
- g. Postamble (Not selectable in ASCII)
- h. Quality Indicator
- i. Data Format
- j. Loss & Error Data Bits

Note: The asterisk (*) after the baud rate, stop bits and parity indicate that when these values are changed, the UART needs to be reloaded. There are three ways to load the UART:

- a. Power down the TM7000 and power it up again.
- b. Disconnect the RS-232 cable and reconnect it.
- c. Move SW4-8 to the ON position and then back OFF.

***** CAUTION *****

If one of these steps are not done the UART will not reconfigure to the new settings.

The user should select the appropriate settings for their needs. A brief description of each of the subdivisions follows.

A. ASCII/BCD FORMAT (Switch S1)

When the ASCII format is selected, each byte will be an ASCII character as detailed in Table One and One-A. The last two bytes are always CR and LF. The preamble byte and the two quality bytes are optional. This format is simple to process, since all characters are ASCII, but each digit requires a full byte.

When one of the various BCD formats is selected, two digits are packed into each byte. These formats are more difficult to process, since each decimal digit must be masked and extracted from the byte, but the time message can be transmitted faster, since fewer bytes are required.

The word length and the data in each byte are shown in the tables in Section 3.12.8.



SW. #	SW. POSITION	DESCRIPTION
5	ON (0)	ASCII
	OFF (1)	BDC (DEFAULT)

In the above example, switch S1 position 5 “ON” selects the ASCII mode.

B. BAUD RATE (Switch S2)

This assembly is capable of generating fifteen baud rates. They are 50, 75, 110, 134.5, 150, 200, 300, 600, 1200, 1800, 2400, 4800, 9600, 19200 and 38400. For the required switch settings for each of the baud rates, please refer to the table on the following page.

C. STOP BIT (Switch S2)

There are three possible settings for the stop bit: 1, 1.5 and 2. The 1.5 setting is used for some old teletype equipment, which does not apply here. Generally, use 1 or 2 stop bits.

D. PARITY (Switch S2)

There are three possible settings for parity: none, odd and even. The settings are valid in both ASCII and BCD message formats. If parity is set to odd or even, then the parity will be added to the output word. For example, if the UART is set to 8 data bits, 1 stop bit and odd parity, then the entire transmitted word is 11 bits in length (1 start bit + 8 data bits + 1 parity bit + 1 stop bit = 11 bits).

E. WORD LENGTH (Switch S4)

The word length can be varied in both BCD and ASCII message format. The user can choose between 7 or 8 bits.

*** CAUTION ***

If the word length is set to 7 bits while using the packed BCD format, the most significant bit of some digits will be lost and an irrational time message will be transmitted. Always select the 8-bit word length when using the BCD output format.

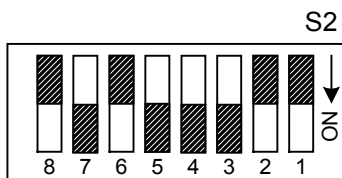

SW #1	SW #2	SW #3	SW #4	BAUD RATE
ON (0)	ON (0)	ON (0)	ON (0)	50

ON (0)	ON (0)	ON (0)	OFF (1)	75
ON (0)	ON (0)	OFF (1)	ON (0)	110
ON (0)	ON (0)	OFF (1)	OFF (1)	134.5
ON (0)	OFF (1)	ON (0)	ON (0)	150
ON (0)	OFF (1)	ON (0)	OFF (1)	200
ON (0)	OFF (1)	OFF (1)	ON (0)	300
ON (0)	OFF (1)	OFF (1)	OFF (1)	600
OFF (1)	ON (0)	ON (0)	ON (0)	1200
OFF (1)	ON (0)	ON (0)	OFF (1)	1800
OFF (1)	ON (0)	OFF (1)	ON (0)	2400
OFF (1)	ON (0)	OFF (1)	OFF (1)	4800
OFF (1)	OFF (1)	ON (0)	ON (0)	9600
OFF (1)	OFF (1)	ON (0)	OFF (1)	19200
OFF (1)	OFF (1)	OFF (1)	ON (0)	38400
OFF (1)	OFF (1)	OFF (1)	OFF (1)	38400

SW #5	SW #6	STOP BITS
ON (0)	ON (0)	1 (DEFAULT)
ON (0)	OFF (1)	1
OFF (1)	ON (0)	1.5
OFF (1)	OFF (1)	2

SW #7	SW #8	PARITY
ON (0)	ON (0)	NONE
ON (0)	OFF (1)	ODD
OFF (1)	ON (0)	EVEN
OFF (1)	OFF (1)	NONE (DEFAULT)

In the above example, the BAUD rate is 9600, with 1 stop bit and odd parity.

F. PREAMBLE (Switch S1)

The preamble is always a hex 02 character (ASCII character STX = Start of Text). If enabled, this will be the first byte out in either the ASCII or BCD message format.

G. POSTAMBLE (Switch S1)

The postamble is automatically inserted into the ASCII format. It is optional in the BCD format. The postamble comprises hex 0D, hex 10 (ASCII CR, LF) at the end of the message.

H. QUALITY INDICATOR (SWITCH S1)

The quality indicator can be enabled in either ASCII or BCD format. Depending on the BCD format selected, a binary one in a specific location indicates an error in the input time code, while a binary one in a different specific location indicates a loss of the input time code signal. Refer to the tables on the following pages for the specific location of the Error and Loss bits for each format. In the ASCII format two bytes are used for the quality indicator (Quality 1 and Quality 2). Quality 1 byte is set to ASCII “L” (hex 4C) indicating a loss of time code input signal. Quality 2 byte is set to ASCII “E” (hex 46) indicating an error in the input time code. An ASCII “space” (hex 20) is set in both Quality 1 and 2 if there are no errors.



SW. #	SW. POSITION	DESCRIPTION
6	ON (0)	PREAMBLE
	OFF (1)	NO PREAMBLE

SW. #	SW. POSITION	DESCRIPTION
7	ON (0)	QUALITY INDICATOR
	OFF (1)	NO QUALITY INDICATOR

SW. #	SW. POSITION	DESCRIPTION
8	ON (0)	POSTAMBLE
	OFF (1)	NO POSTAMBLE (DEFAULT)

I. DATA FORMAT (Switch S4)

The BCD output data can be formatted to start with Days and go through Milliseconds, or start with Milliseconds and go through Days.

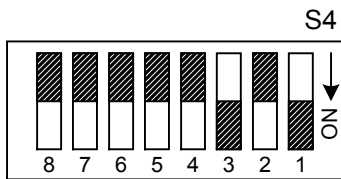

SW. #	SW. POSITION	DESCRIPTION
5	ON (0)	BCD DAYS THRU MILLISECONDS
	OFF (1)	BCD MILLISECONDS THRU DAYS (DEFAULT)
6	ON (0)	DISABLE LOSS AND ERROR
	OFF (1)	ENABLE LOSS AND ERROR (DEFAULT)

In the example shown, the BCD output data format is milliseconds through days and the Loss and Error bits are enabled.

J. LOSS AND ERROR DATA (Switch S4)

Loss and Error bits can be enabled or disabled within the applicable data format. This does not apply to the preamble or postamble.

3.12.7 OPERATION

When power is applied to the TM7000, this talker will begin to operate.

The time data that is output by this talker can be selected (by a jumper) per one of the following three modes:

- Automatic The time that is displayed on the front panel is the time that is output.
- Generator Only the generated time will be output.
- Translator Only the translated time will be output.

Note: If the talker is selected to output translator time, and there isn't a code input to the unit, the time output will be invalid.

Time data jumper selection:

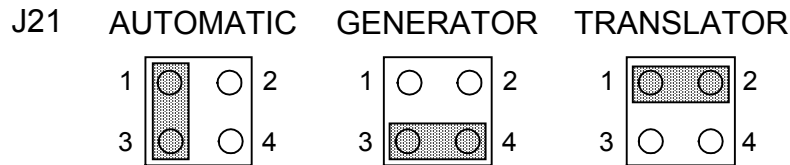

3.12.8 TIME WORD OUTPUT FORMATS (RS-232 TALKER):

Following are shown the various RS-232 Talker Output Word Formats. Regardless of how they appear, a Start bit, Parity, and Stop bit(s) are always included as part of the format.

**TABLE 3-3
ASCII Format Time Word Output
All Options On**

	7	6	5	4	3	2	1	0	
Word #1 Preamble	0	0	0	0	0	0	1	0	Optional
Word #2	0	0	1	1	HD				
					8	4	2	1	
Word #3	0	0	1	1	TD				
					8	4	2	1	
Word #4	0	0	1	1	UD				
					8	4	2	1	
Word #5	0	0	1	1	0	0	TH		
							2	1	
Word #6	0	0	1	1	UH				
					8	4	2	1	
Word #7	0	0	1	1	0	TM			
						4	2	1	
Word #8	0	0	1	1	UM				
					8	4	2	1	
Word #9	0	0	1	1	TS				
						4	2	1	
Word #10	0	0	1	1	US				
					8	4	2	1	
Word #11	0	0	1	1	tS				
					8	4	2	1	
Word #12	0	0	1	1	hS				
					8	4	2	1	
Word #13	0	0	1	1	mS				
					8	4	2	1	
Word #14 Quality 1	0	1	0	0	1	1	0	0	Optional Loss
Word #15 Quality 2	0	1	0	0	0	1	0	1	Optional Error
Word #16 CR	0	0	0	0	1	1	0	1	
Word #17 LF	0	0	0	0	1	0	1	0	

In order to output the format shown in Table 3-3, set the RS-232 select switches as follows: (Specific configurations such as Mode and BAUD rate etc. aren't shown).

SWITCH LOCATION AND SECTION	SWITCH POSITION	DESCRIPTION
S1 section 5	ON (0)	ASCII selected
S1 section 6	ON (0)	Preamble selected on
S1 section 7	ON (0)	Quality Indicator selected
S1 section 8	OFF (1)	Postamble selected off
S4 section 2	OFF (1)	8 Bit Word selected

TABLE 3-4
ASCII Format Time Word Output
No Options

	7	6	5	4	3	2	1	0
Word #1	0	0	1	1	HD			
					8	4	2	1
Word #2	0	0	1	1	TD			
					8	4	2	1
Word #3	0	0	1	1	UD			
					8	4	2	1
Word #4	0	0	1	1	0	0	TH	
							2	1
Word #5	0	0	1	1	UH			
					8	4	2	1
Word #6	0	0	1	1	0	TM		
						4	2	1
Word #7	0	0	1	1	UM			
					8	4	2	1
Word #8	0	0	1	1	0	TS		
						4	2	1
Word #9	0	0	1	1	US			
					8	4	2	1
Word #10	0	0	1	1	tS			
					8	4	2	1
Word #11	0	0	1	1	hS			
					8	4	2	1
Word #12	0	0	1	1	mS			
					8	4	2	1
Word #13 30H	0	0	1	1	0	0	0	0
Word #14 CR	0	0	0	0	1	1	0	1
Word #15 LF	0	0	1	1	1	0	1	0

CHAPTER THREE

In order to output the format shown in Table 3-4, set the RS-232 select switches as follows: (Specific configurations such as Mode and BAUD rate etc. aren't shown).

SWITCH LOCATION AND SECTION	SWITCH POSITION	DESCRIPTION
S1 section 5	ON (0)	ASCII selected
S1 section 6	OFF (1)	Preamble selected off
S1 section 7	OFF (1)	Quality Indicator selected off
S1 section 8	OFF (1)	Postamble selected off
S4 section 2	OFF (1)	8 Bit Word selected

**TABLE 3-5
BCD Format Time Word Output
All Options On**

	7	6	5	4	3	2	1	0	
Word #1 Preamble	0	0	0	0	0	0	1	0	Optional
Word #2	0	0	0	0	HD				
Word #3	TD				UD				
Word #4	0	0	TH		UH				
Word #5	0	TM			UM				
Word #6	0	TS			US				
Word #7	tS				hS				
Word #8	mS				0	0	0	0	
Word #9 Quality	0	0	0	0	0	0	L	E	Optional
Word #10 Postamble	1	1	0	1	1	0	1	0	Optional

In order to output the format shown in Table 3-5, set the RS-232 select switches as follows: (Specific configurations such as Mode and BAUD rate etc. aren't shown).

SWITCH LOCATION AND SECTION	SWITCH POSITION	DESCRIPTION
S1 section 5	OFF (1)	BCD selected on
S1 section 6	ON (0)	Preamble selected on
S1 section 7	ON (0)	Quality Indicator selected on
S1 section 8	ON (0)	Postamble selected on
S4 section 2	OFF (1)	8 Bit Word selected
S4 section 5	ON (0)	Format Days-mS selected
S4 section 6	ON (0)	Loss and Error bits disabled*

* This does not apply to the Quality Indicator Word #9.

TABLE 3-6
BCD Format Time Word Output
No Options

	7	6	5	4	3	2	1	0
Word #1	0	0	0	0	HD			
					8	4	2	1
Word #2	TD				UH			
	8	4	2	1	8	4	2	1
Word #3	0	0	TH		UH			
			2	1	8	4	2	1
Word #4	0	TM			UM			
		4	2	1	8	4	2	1
Word #5	0	TS			US			
		4	2	1	8	4	2	1
Word #6	tS				hS			
	8	4	2	1	8	4	2	1
Word #7	mS				0 0 0 0			
	8	4	2	1				

In order to output the format shown in Table 3-6, set the RS-232 select switches as follows: (Specific configurations such as Mode and BAUD rate etc. aren't shown).

SWITCH LOCATION AND SECTION	SWITCH POSITION	DESCRIPTION
S1 section 5	OFF (1)	BCD selected on
S1 section 6	OFF (1)	Preamble selected off
S1 section 7	OFF (1)	Quality Indicator selected off
S1 section 8	OFF (1)	Postamble selected off
S4 section 2	OFF (1)	8 Bit Word selected
S4 section 5	ON (0)	Format Days-mS selected
S4 section 6	ON (0)	Loss and Error bits disabled

**TABLE 3-7
Packed BCD Format**

	STOP	STOP	PARITY	D 8	D 7	D 6	D 5	D 4	D 3	D 2	D 1	START
WD1	1	1	X	hs				ms				0
				8	4	2	1	8	4	2	1	
WD2	1	1	X	0	0	0	0	ts				0
								8	4	2	1	
WD3	1	1	X	0	TS			US				0
					4	2	1	8	4	2	1	
WD4	1	1	X	0	TM			UM				0
					4	2	1	8	4	2	1	
WD5	1	1	X	L O S	E R R	TH		UH				0
						2	1	8	4	2	1	
WD6	1	1	X	TD				UD				0
				8	4	2	1	8	4	2	1	
WD7	1	1	X	0	0	0	0	HD				0
								8	4	2	1	

In order to output the format shown in Table 3-7, set the RS-232 select switches as follows:
(Specific configurations such as Mode and BAUD rate etc. aren't shown).

SWITCH LOCATION AND SECTION	SWITCH POSITION	DESCRIPTION
S1 section 5	OFF (1)	BCD selected on
S1 section 6	OFF (1)	Preamble selected off
S1 section 7	OFF (1)	Quality Indicator selected off
S1 section 8	OFF (1)	Postamble selected off
S4 section 2	OFF (1)	8 Bit Word selected
S4 section 5	OFF (1)	Format mS-Days selected

TABLE 3-8
BCD Format Time Word Output
No Options

	7	6	5	4	3	2	1	0
Word #1	E	L	0	0	HD			
					8	4	2	1
Word #2	TD				UH			
	8	4	2	1	8	4	2	1
Word #3	0	0	TH		UH			
			2	1	8	4	2	1
Word #4	0	TM			UM			
		4	2	1	8	4	2	1
Word #5	0	TS			US			
		4	2	1	8	4	2	1
Word #6	tS				hS			
	8	4	2	1	8	4	2	1
Word #7	mS				0 0 0 0			
	8	4	2	1				

In order to output the format shown in Table 3-8, set the RS-232 select switches as follows: (Specific configurations such as Mode and BAUD rate etc. aren't shown).

SWITCH LOCATION AND SECTION	SWITCH POSITION	DESCRIPTION
S1 section 5	OFF (1)	BCD selected on
S1 section 6	OFF (1)	Preamble selected off
S1 section 7	OFF (1)	Quality Indicator selected off
S1 section 8	OFF (1)	Postamble selected off
S4 section 2	OFF (1)	8 Bit Word selected
S4 section 5	ON (0)	Format Days-mS selected
S4 section 6	OFF (1)	Loss and Error bits disabled

This Page Intentionally Left Blank

CHAPTER FOUR

THEORY OF OPERATION

4.0 LOGIC DESCRIPTION AND USE

The TM7000 TymMachine TCG/T is depicted by several drawings. One of these drawings is the Top Assembly drawing A-TM7000 which shows the physical location of the assemblies that are contained in this instrument. This print should be used to locate connectors on the rear panel and for quick reference to the physical location of any of the assemblies and controls.

Schematics are comprised of sheets, with each individual sheet number referenced in the lower right-hand corner of the title block. Each term on a schematic sheet will have a name and may or may not have a number in brackets [] preceding or following it. This number in brackets [] (i.e. the term reference number) indicates the sheet number where that term originates. Example: [2] OSCLK. This says that the term “OSCLK” shown on Sheet 3 actually originates on Sheet 2. If the origin of the term is on the same sheet as the term, it won’t have any brackets. This provides a convenient means of getting back and forth from various pages of the schematic.

Each time a term reference number appears, it will refer you back to the source of that signal. In each of the schematics there will be a number such as U4, U8, U11 etc. These numbers refer to the physical location on this assembly for that particular integrated-circuit element. In order to determine a physical location of an integrated circuit, one would merely refer to the Top Assembly drawing. On this drawing, each assembly contained within the Basic instrument is identified by referencing the mechanical view of the top of the instrument. Look for the printed circuit board of interest. Examine the board until the desired integrated circuit or component is located.

All references in this discussion will be based on the sheet numbers located in the Title Blocks of the schematics. The reader should be familiar with the above before proceeding.

4.1 GENERAL

The TymMachine is both a Time Generator and a Time Translator. A Time Generator is a device which takes a reference frequency and divides it so as to accumulate or “count” time intervals. A Time Translator is a device which requires a Serial Coded input and “decodes” or “translates” this input to some other form, usually parallel time data.

In order to better understand the logic organization of the TymMachine, lets first review the basic configuration of typical timing units.

CHAPTER FOUR

Figure 4.1.1 shows a simplified diagram of a typical Time Code Generator. The significant sections of a Time Code Generator are:

- Frequency Source – Usually a crystal controlled oscillator.
- Minor Time Counters – The purpose of these counters is to develop scan terms and rates required to develop the Serial Code format or to be used for parallel outputs. They also supply a 1PPS signal that is used to update the Major Time Accumulator.
- Major Time Accumulator – This section is a counter whose function is to store the Time-of-Year data. It is incremented by the 1PPS clock output of the Minor Time. Its outputs are buffered and used for parallel outputs or are scanned by the Encoder and output in a serial format.
- Counter Control – This section synchronizes the time accumulators (Minor Time) and includes switches to select and enter the Time-of-Day into the Major Time Accumulator.
- Parallel-to-Serial Converter – This section consists of scan gates that serialize the contents of the accumulator into a continuous pulse train.
- Formatter – This section uses pulse rates from the Minor Time Counter to obtain the pulse widths and index pulses required to provide the format defined by the type of time code being generated. This format is then usually combined with a sine wave to provide an amplitude-modulated signal.
- Output Amplifier – This section provides the required output drive and signal levels of the formatter output.
- Display – This section provides a visual interface between the Generator and the operator.

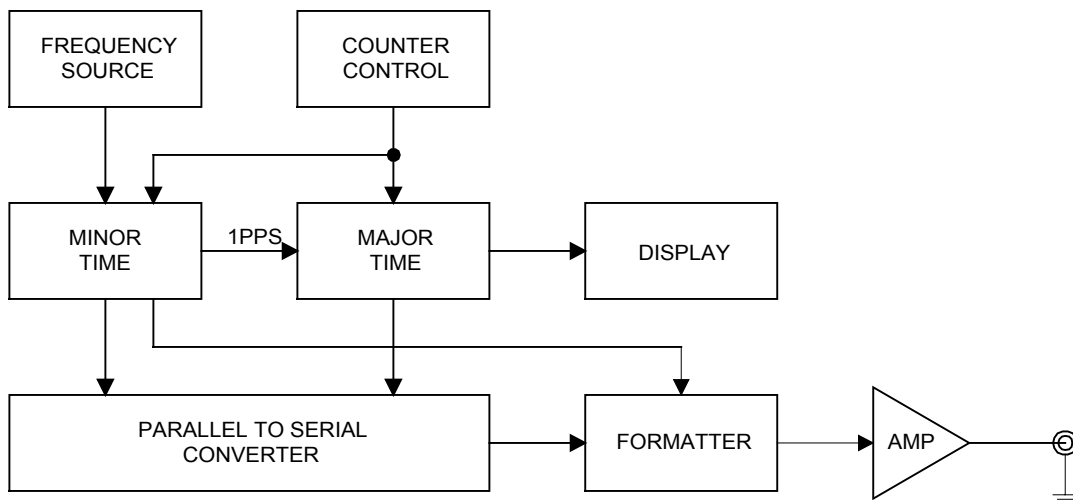

Figure 4.1.1
Typical Time Code Generator

Figure 4.1.2 shows a simplified diagram of a typical Time Code Translator. The significant points of a Time Code Translator are:

- Input Amplifier – Usually this is an AGC (Automatic Gain Control) type amplifier. Its function is to provide a constant amplitude signal to the decode and detection circuitry.
- Serial-to-Parallel Converter – This is the heart of the unit. It's function is to detect digital data in the input format and assign it to storage in the Time Accumulator. This portion contains the necessary circuits to synchronize the frequency dividers.
- Frequency Dividers – These counters divide the carrier frequency. Once synchronized by decoding circuitry in the Serial-to-Parallel section, this counter provides the terms necessary to index the digital data contained in the input code. This allows the locating of each code bit and the proper assignment to accumulator storage. They also provide a 1PPS signal to update the Time Accumulator.
- Time Accumulator – This counter stores the value being read from the input code. It is updated with the 1PPS signal from the Frequency Dividers and is permuted to count in the format of the input Time Code (usually Seconds, Minutes and Hours). Day-of-Year is provided if it is contained in the input Time Code. The Time Accumulator is the basis for most outputs provided by the unit.
- Display – This section takes the Time Accumulator data and displays it to the user.

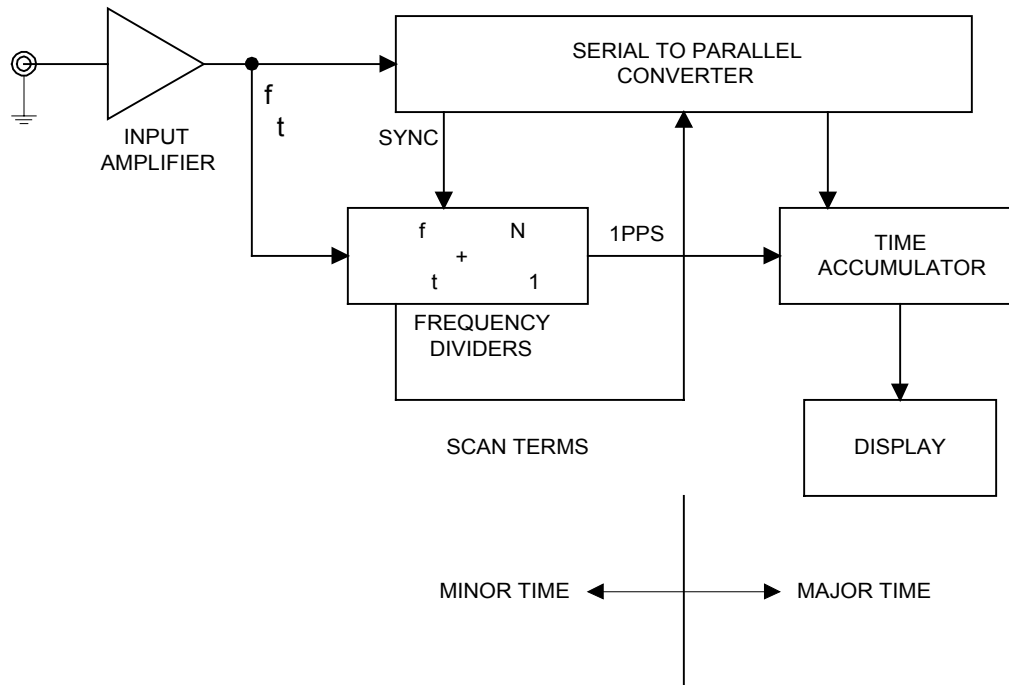

Figure 4.1.2
Typical Time Code Translator

CHAPTER FOUR

Now if we combine the two functions, taking advantage of circuitry found common to both, we obtain a Time Code Generator/Translator (Figure 4.1.3). Logic functions, which are common, i.e., those which need not be duplicated are:

- Operator controls
- Display

The Power Supply and Chassis are shared.

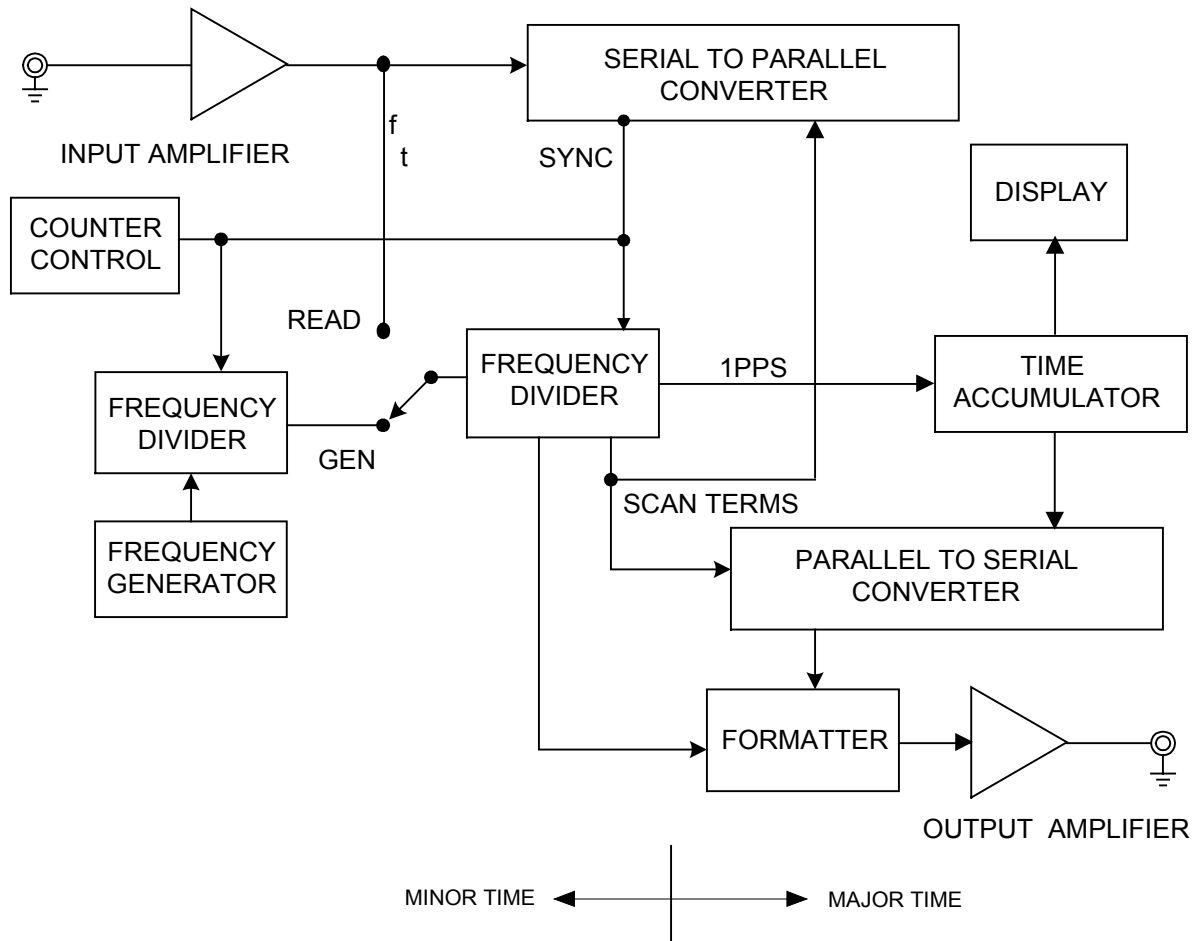

Figure 4.1.3
Typical Time Code Generator/Translator

4.2 DETAILED LOGIC DESCRIPTION

This description will be referenced only to the sheet numbers that are contained within the Title Block of each individual schematic. Before proceeding, the reader should be familiar with paragraph 4.0, LOGIC DESCRIPTION AND USE.

It is also important to keep in mind that while the simplified block diagrams presented are conceptually accurate, the functions are performed by a mixture of hardware and firmware. A functional block diagram of the TM7000 TymMachine may be found in Figure 4.2.1.

The TymMachine is a Microprocessor based system. The Microprocessor used, a 65C02, has an eight bit data bus and a non-multiplexed 16 bit address bus. The processor in the GENERATOR assembly is used as a system controller for handling internal and external (Optional) I/O as well as the user interfaces: Time Display, LCD Display and Keyboard.

Most hardware logic functions are provided by U23 [15] a PLD which is programmed by U25 [4] at power up.

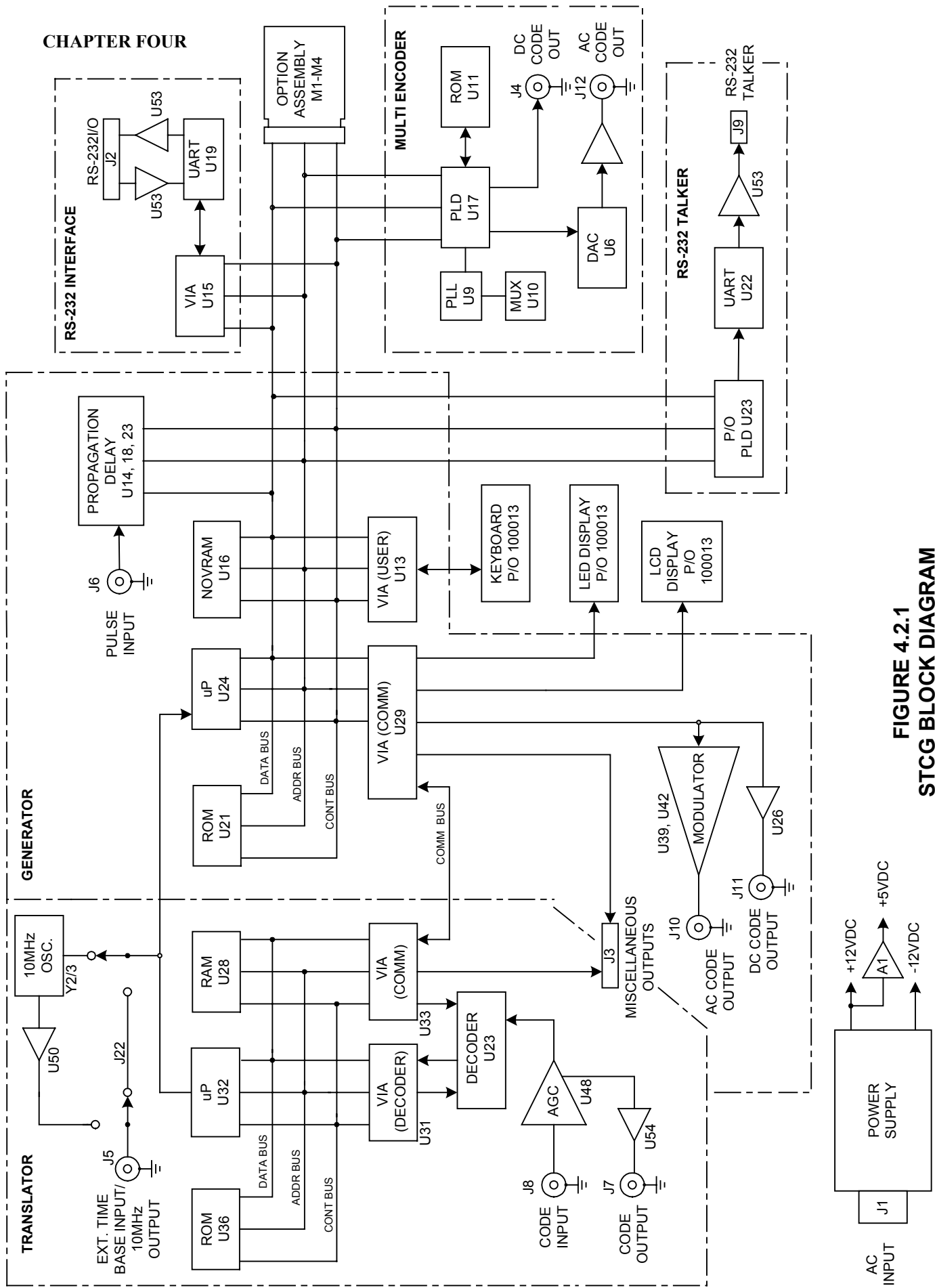

FIGURE 4.2.1
STCG BLOCK DIAGRAM

4.3 [5] STCG (I/O and DAC)

The primary function of this logic is to show the interconnections between the GENERATOR and other assemblies. Interconnect to the Keyboard is shown on [3]. Logic terms originating on this assembly have their origins indicated using the term referencing system. Terms for which no reference is shown originate elsewhere (if at all) in the instrument. Many of the signals, which appear here, are bi-directional.

This logic also shows the Standby Battery and the Charging circuitry. The adjustment circuit for the LCD Display contrast (R9) is also shown here.

U35, the Digital to Analog Converter is used to steer the Oscillator frequency.

4.4 [4] STCG (PROP DELAY)

When an External Reference Frequency is input, it is terminated (at about 50 Ohms) by R182, and converted to a logic level by Schmidt trigger U49. The output of this Schmidt trigger is applied to U 23 which selects the external input (if present) or the internal 10MHz oscillator for division to 62.5 KHz (SELREF).

Y2 (or Y3) provides a precision 10MHz which, after conversion to logic levels by U51 is the internal time reference for the TymMachine. When an external reference is not used, the internal reference may be output via U50, J22 (jumper 1-2), and J5. The level may be adjusted with R184.

U14 is a programmable counter which measures the time between the generated 1PPS and the reference (from translator or external 1PPS) to start or steer the generator. U18 is a digitally programmable one-shot used to implement vernier (100nS) propagation delays. U25 holds the configuration data for the PLD, U23.

4.5 [6] STCG (GENERATOR CODE)

This logic includes derivation of the Microprocessor Clock, which is also used for timekeeping, IRIG B output circuits, and circuits for Power-on reset.

SELREF is one input to a Phase Detector and VCO (U38). The other Phase Detector input is VCO divided by 32 in U23. Action of the Phase Locked Loop forces the VCO to operate at 2MHz (nominal) with the stability of the selected reference oscillator. The VCO output Ø2-IN is used as a clock for the Microprocessor and as the reference frequency for timekeeping.

The IRIG B output circuits bandpass filter a 1KHz square wave to provide a 1KHz sine wave at the output of U39 pin 7. The part of U39, whose output is pin 1, is operated as a follower with gain. With FET switch Q2 ON, the gain determined by R24 and R26 is approximately 15. When Q2 is OFF, the gain determined by R24, R27 (ratio) and R26 is approximately 5 (depending upon adjustment of R27). Switching Q1 ON and OFF with the DC Shift form of IRIG B causes the output at U39 pin 1 to be a 3:1 Amplitude-Modulated signal.

CHAPTER FOUR

The output of U39 pin 1 is attenuated by R101 (LEVEL) and buffered by U42 to provide a low impedance IRIG B AC Code OUT.

Power status is provided by U20, which monitors the +12V. Power status is important during both the Power-UP and Power-Down transitions. During Power-Up U20 holds PON (Power ON) low until +12V is high enough to provide a regulated +5V for the logic. PRES/ goes to U23 where RES/ is generated following configuration of U23. RES/ is used throughout the TymMachine to initialize hardware to a known status. Following RES/, a Firmware startup procedure is performed. Then the main program executes. When power is lost for any reason, PON goes false forcing NMI/ false. Following shutdown, the status of PON is monitored to provide program recovery without a Reset if the power failure was momentary

4.6 [2] STCG (GENERATOR μ P)

This logic contains the heart of the Microprocessor: the Microprocessor-controller, the ROM-program storage, and the RAM-variable storage.

The Microprocessor (U24) is an 8 bit CMOS device. It accepts as an input clock \emptyset 2-IN and outputs \emptyset 2 clock.

Other inputs are the non-maskable interrupt (NMI/), the maskable interrupt (IRQ/), and Reset (RES/). The data lines (D0-D7) are bi-directional. The address lines (A0-A15) are outputs. The ROM (U21) contains the program, which the Microprocessor executes. When an address of 1000 Hex or more is on the address bus, the ROM outputs to the data bus while \emptyset 2 is high. The RAM (U16) is used for temporary storage of data and variables.

The RAM used in the TymMachine is a combination of static RAM (SRAM) and electrically erasable PROM (E²PROM). The internal configuration provides a byte of E²PROM for every byte of RAM. In normal system operation, all reads and writes are to the RAM, but when power fails, every byte of RAM is written to E²PROM. When power returns, each byte of E²PROM is written to RAM. This feature enables the TymMachine to remember user entered configuration information during any power outage.

The RAM is disabled for all addresses above X3FF Hex by U23, as the addresses are used by options and ROM. The RAM is also disabled for addresses in the range XXE0-XXFF by U23, permitting the VIA's [3] to use that range.

U23 is used to decode I/O1 through I/O7 which are used to enable option assemblies, and I/O0. I/O0/ through I/O7/ correspond to addresses N400 Hex-NFFF Hex when N is the I/O number 0-7.

Interrupt requests from the options are connected to IR1/-IR6/. When any of these lines is asserted (low), an output from U23 goes low asserting IRQ/. When interrupt request is processed, reading I/O0 puts the address of the interrupt source with highest priority on to the data bus provided by a priority encoder in U23.

4.7 [3] STCG (GENERATOR VIAS)

U13, VUSR, and U29, VCOM, are Versatile Interface Adapters (VIA). Each of them contains 2-8 bit I/O ports with handshaking, 2-16 bit counters, an 8 bit shift IN-or-OUT register, and extensive interrupt capabilities.

All of the functions of the VIAs are under program control, and many of them are changed dynamically. As a convenience, the VIAs have been named according to their primary function. VUSR provide user interface via the Keyboard. VCOM provides communication with the Translator Assembly. One of the counters of VUSR counts $\emptyset 2$ to generate 100KHz. This 100KHz becomes the reference frequency for the Generator. It is further divided by U23 to provide 10KHz, which interrupts VUSR (at CA1) to “clock” the Firmware Minor Time. 10KHz is further divided by hardware (U23) to 1KHz which becomes the IRIG B carrier after filtering. VUSR, CB2, provides the signal GEN 1PPS, which is used to Start/Stop the counter chain, and also to synchronize it to the Firmware Minor Time. This synchronizing signal does not appear once per second and may occur only rarely. VUSR PA0-PA7 are used to service the Keyboard. The Keyboard is a 4X4 matrix. It is periodically scanned for a connection. If a connection (closure) exists, it is debounced in firmware, then acted upon. Due to the scanning technique, simultaneous closures are not permitted. VCOM, CA2, is used as an inhibit to prevent I/O interrupts during time sensitive parts of the program.

The second counter in VUSR generates periodic interrupts which are used to debounce the Keyboard. VUSR PB0 outputs W/, which is used to write to the LED Display. VUSR, PB1, outputs ENL, which enables the LCD Display.

VUSR, CA2, is used as a Power Fail (FP) output during the Power-Down sequences to prevent multiple sequencing. VUSR, PB4 is used as a Clock Inhibit (C1H) for the Backup Clock. VUSR, PB5, is used as an input to sample the Power-On (PON) status during Power-Down and Power-Up sequence. This permits optional circuitry to store the Generator Time for subsequent Serial or Parallel output. VUSR, CB1, is an optional input with interrupt capability. Depending on the configuration, it may be used to either Start or Synchronize the Generator.

VCOM, PA0-PA7, and CA1 and CA2 are used for the GEN COMM half of the I/O with the Translator assembly. All lines tie to the corresponding lines of the TRANS COMM except that CA1 and CA2 are crossed. This is a bi-directional data path over which time and other information pass between the Generator and Translator. Data transfer is asynchronous. Data on the PA0-PA7 bus is latched into the receiving bus by a transition on the sending bus CA2 (receiver's CA1). This transition also sets a flag in the receiver's status register. When the flag is discovered, it is acknowledged by a transition on the receiver's CA2 (sender's CA1). Generally transfer to the Translator causes an interrupt (in the Translator) while that to the Generator merely sets a flag which must be polled to be recognized. In some cases however, the Generator is enabled to be interrupted.

VCOM, PB0-PB3, are used as data outputs to the Backup Clock U1, the LCD Display, and the LED Displays. VCOM, PB4-PB6, are used, in conjunction with C1H, to write an address, write

CHAPTER FOUR

data, or read data, respectively to the Backup Clock. When writing to the LED Display, W/ is used to store data into the display driver with the digit address provided by VCOM PB4-PB6. PB7 provides decimal point information. The Seconds digit is written by LDUS/. VCOM, PB4, is a register select to the LCD Display. VCOM, PB5, functions as a read/write control for the LCD Display. As previously mentioned, ENL is used to clock transfers to the LCD Display.

U52 and part of U26 are used to buffer output signals.

CAUTION

The TymMachine will not operate without a functioning LCD Display connected. The LCD Display is a Microprocessor based subsystem, which must interact with the Generator Microprocessor for correct operation. Also note that the pin numbers shown at J103 on [5] do not correspond to the LCD Display manufacturer's data. This is because different numbering systems are used.

Finally VCOM, CB1 and CB2 are used to shift out the DC envelope (DCC/) of the IRIG B Serial Time Code. CB1 is the clock input and CB2 is the shift register output.

Table 4-1
Rear Panel BNC Connections

BNC Connector	Signal
J4	Multi – Code DC Code Output
J5	Ext. Time Base Input or 10MHz Sine Wave Output
J6	Pulse/1PPS Input
J7	AGC Output
J8	Code Input
J10	IRIG B AC Code Output
J11	IRIG B DC Code Output
J12	Multi – Code AC Code Output

**Table 4-2
Rear Panel Connector J3 Signals**

Connector J3 Pin	Signal	Source
1	Pulse Rate 1KPPS	Generator
2	Pulse Rate 100PPS	Generator
3	Pulse Rate 10PPS	Generator
4	Pulse Rate 1PPS	Generator
5	Carrier	Translator
6	Carrier /10	Translator
7	Carrier /100	Translator
8	Carrier 1K	Translator
9	Ground	Generator
10	IRIG DC Level Shift Output	Generator
11	LOSS	Translator
12	ERR	Translator
13	Not Used	N/A
14	Not Used	N/A
15	Not Used	N/A

4.8 [7] (TRANSLATOR AGC)

The regulator shown at A1 is used to generate the – 5 Volt power for the Translator Assembly.

This logic contains the input amplifier AGC and the code strippers required to normalize the input and to derive the necessary clock signals for the decoder.

The AGC amplifier is wide band to make the unit operational where variations of input signal frequency as well as amplitude are experienced such as in Tape Search applications.

Generally if a Translator is used as a single purpose unit such as to only translate code at a single rate and display it, the AGC circuits can be narrow band. To make the unit more adaptable to different types of applications, we have provided a 100 mV to 10 Volt dynamic range and a frequency response of 30Hz to 2MHz. The circuit does not require adjustment over this range.

CHAPTER FOUR

The input signal is AC coupled by C143 through R149 to attenuator FET Q4. Q4 is employed as a voltage controlled resistor to maintain a constant level at the input of U48 of approximately 13 mV Peak-to-Peak. It is not recommended to observe this signal. U48 provides a gain of 14 yielding about 180 mV Peak-to-Peak at U46-13 and the FILT INPUT [9]. U46 is an Analog Switch. U46, pins 1, 2, 10 and 15, are used to provide signal inversion by controlling whether the Plus or Minus input at U47 is driven. The input of U46 at pin 15 comes from the output of U41 pin 6 [9]. U47 provides a gain of about 9 so that the AGC signal is a constant 2 Volts Peak-to-peak at TP2.

Analog Switch, U46 pins 12, 13, and 14 are used to route the code (C) to the input of amplifier U41 [9] when the Envelope Filter is not used (OFF).

Completing the AGC loop, U44, pins 15, 16, and 13 are controlled by comparing AGC with $-1V$. When the negative peak of AGC exceeds $-1V$, Q3 supplies current to C141, which raises the voltage at the gate of FET Q4, lowering its resistance and decreasing the input to U48. When Q3 is not conducting R137 pulls C141 minus increasing the resistance of Q4. R140 provides fast recovery when loss of activity is detected at AS1 (Activity Sensor 1). The AGC signal is applied to the output buffer U54 and to the $\emptyset B$ and $\emptyset C$ detectors U44 pin 7, and U44 pin 9. $\emptyset B$ detector, U44 pins 7, 8, and 5, is a zero crossing detector with hysteresis on the negative edge. The positive (on-time) edge coincides with the positive zero crossing of the input code. $\emptyset C$ detector U44, pins 9, 10, and 12, detects the Mark Amplitude cycles of the input code. $\emptyset B$ and $\emptyset C$ are used by the decoders which are located in U23 $\emptyset C$ is also used by the activity sensing circuitry described above. A secondary function of the activity sensor is to increase the threshold of the $\emptyset C$ detector at pin 10 slightly to provide hysteresis for AS1.

Shown in the lower left of this logic is the LOS (Loss of Signal) circuitry U44 pin 4. This circuit senses peak amplitudes of the input signal versus an adjustable threshold established by potentiometer R135 (THOLD).

4.9 [8] STCG (TRANSLATOR μP)

This logic contains the heart of the Translator: The Microprocessor-Controller (U32), the ROM (U27) - program storage, and the RAM (U28) - variable storage. Also included are the VIA's for communications and decoding.

The Microprocessor is an 8 bit CMOS device. It accepts as an input clock $\emptyset 2$ -IN and outputs $\emptyset 2$.

Other inputs are the non-maskable interrupt (NMI/), the maskable interrupt (IRQ), and RESET (RES/). The data lines (D0-D7) are bi-directional. The address lines (A0-A15) are outputs. The ROM contains the program, which the Microprocessor executes. When an address of 8000 Hex or more is on the address bus, the ROM outputs to the data bus while $\emptyset 2$ is high.

The RAM is used for temporary storage of data and variables. The RAM is disabled for all addresses above 007F Hex by U23 as the addresses are used by the VIA's and ROM.

RES/ and Ø2-IN come from the Generator, otherwise, the Translator Microprocessor is a totally independent system. It cannot operate independently however, because all user I/O i.e. Keyboard and Display, is provided by the Generator, via the GEN/TRANS COMM port. This port is part of VIA U33. For a description of the operation of the COMM port see [3] GENERATOR VIAS. In addition U33 provides the data (SRD) and clock (SRC) to set-up shift registers located in U23.

U26, pins 6 and 14, inverts the LOS/ signal from the AGC and provides LOS (Loss of Signal to U33 where it is monitored.

The heart of the decoder is a look-up table in U27, a ROM . U27 is addressed by the ROM address counters and the output of the forward flip-flop located in U23. The ROM address counters in U23 are synchronized by FS.

A left/right shift register in U23 is used to convert the code to binary data. SREN occurs at the correct time to discern whether the code bit is a zero or a one. SREN is so spaced (in time) that the data shifted produces a group BCD (in the case of most codes) at SR outputs TDB0-TDB7.

When a group has been assembled, U27 outputs Byte Ready Enable (TBREN). TBREN is synchronized and then input to U31, a Versatile Interface Adapter (VIA). TBRDY latches the time data into the VIA. It also latches U27 outputs TBA0-TBA3 into the VIA. TBA0-TBA3 are validating bits. When these bits are latched, the VIA issues an interrupt to the Microprocessor which then performs the firmware part of the decoding process.

Once per frame, U27 outputs Frame Ready Enable (TFREN). This signal is used to generate FRP which is on-time with the input code (in the forward direction). FRP is used by the Microprocessor and is also output to the PLD U23, where it synchronizes the Translator Pulse Rates and, in Synchronized Generator modes, the Generator.

TRA11-TRA14 select the correct table (according to code and direction) in U27. This data is serially entered into U23 from the VIA U33.

VIA U31 serves various additional functions not previously discussed. ZAD is an input to both CA2 and PB6. At carrier rates of 1KHz and lower CA2 causes an increment of Minor Time. For faster rates, PB6 counts ZAD down, as appropriate, then increments Minor Time. FWD is sensed at PB4 to inform the Microprocessor of the code direction. SHIFT/ is a test output, which initializes many binary devices.

CHAPTER FOUR

4.10 [9] (TRANSLATOR FILTS)

U45, U43 and U41 make up the Low Pass (Envelope) Filter. The input, FILT IN source is from [7]. The Output at pin 6 of U41 is routed through C113 to input F, of U46 at pin 15 [7].

When the Envelope Filter is turned OFF the code C from [7] is routed through amplifier U41. Filter selection is accomplished using RSELA and RSELB of U43 and CSELA and CSELB of U45. These filters are enabled with SR23. Filter selection is preprogrammed in ROM for the selected input code.

A2 is a +5 Volt regulator, which provides the +5 (+5F) volts for Analog Switches U45, and U43. U40, and U46.

U40, U30, U37, U34 and part of U23 make up the Phase Lock Loop (PLL).

TØB/ is input to U37, a Phase Locked-Loop with VCO, at pin 3. U34 is setup as an integrator whose output is inserted into the PLL IC, U37 at pin 9. The VCO output at pin 4 of U37 is routed to the DIV 0 portion of U30. Division of DIV 0, is under program control by the Control portion of U30. The output of DIV 0, 4CAR, is used to clock U23 which outputs TCAR90.

The Analog Switches, U40 are used to select the frequency and range of the Phase Locked Loop.

See Chapter Five, Maintenance, in this manual, for testing of the LPF (Envelope Filter) and the Carrier Filter (PLL). Adjustments to the PLL are also found in Chapter Five.

4.11 [10] RS-232 TALKER

The RS-232 talker is used to “burst” time out periodically. U23 provides the control logic, which is selected by switches S1-S4. U2-U5 are used to multiplex the switch selections into U23 when the unit is powered up. U22 is a UART which formats the output data as selected, and also generates the baud clock by dividing OSCB which comes from Y1 via U26.

4.12 [12] RS-232 I/O

This option provides for remote control and readback via RS-232. The operating program code is contained in the basic generator and these circuits are used to provide level shift to and from bi-polar to 5 volt logic (U53), baud rate generation, RS-232 formatting and decoding {U19}, and an interface between the relatively fast processor bus, and the slower UART (U15). Setup for this option is provided by menus on the LCD.

4.13 [13] MULTI ENCODER

The majority of the circuitry for this function is provided by U17, a programmable logic device (pld) which is programmed by U11. U11 is under control of U12 which can be set up by U17 to provide different ROM addresses which contain the U17 programs corresponding to different encoder functions.

U17 includes storage and counters for the time which is gotten off the processor bus. It also includes dividers and multiplexers to facilitate the generation of different codes and carrier rates.

U17 incorporates a counter which is clocked at one hundred times the output carrier rate. Outputs from the counter drive an internal look-up table whose outputs drive the DAC U6. The reference for the DAC incorporates the DC shift code, so the DAC output is a modulated envelope. This current is converted to a voltage by U7, then buffered and output by U8.

4.14 [14] MULTI ENCODER (PLL)

The one hundred times clock comes from a counter chain driven by the output of U9, a pll which is locked to either the generated 100KHz or the translator ZAD/. U10 is used to select appropriate parts for the loop filter in accordance with the selected frequency and dividers. INH, SEL0, and SEL1 are written by U24 through U17 to U12.

4.15 DISTRIBUTION BOARD (100008)

The TymMachine contains one 100008 Distribution Board Assembly. Option Plug-in Assemblies are installed into the Distribution Board Assembly. This assembly has provisions for installing up to four single wide Option Plug-in modules.

4.16 DISPLAY ASSEMBLY (100009)

The display uses an 8 digit driver (U1) to drive displays DS1-DS8. Data is input over line VCOM, PB0-PB3, with address input on VCOM, PB4-PB6. Line PB7 has decimal point information. W/ is used to store the information. The output of this driver is multiplexed constant current segment, decimal point, and digit drive for 8 LED digits. The ninth digit of the display (US) is driven by U2 a decoder/driver with storage, and U4 which, in combination with U3, drives the top and bottom segments for sixes and nines, respectively. The data presented on VCOM, PB0-PB3, is stored by LDUS/. Resistors R1-R7 limit current to match the intensity of DS9 to the rest of the display.

This assembly also includes the keypad which is implemented with 16 switches in a four by four matrix, and the LCD.

This Page Intentionally Left Blank

CHAPTER FIVE

MAINTENANCE, TROUBLESHOOTING, AND ADJUSTMENTS

5.0 INTRODUCTION

***** CAUTION *****

Care should be used in handling CMOS integrated circuits. Users must remember that CMOS devices can be seriously damaged if subjected to high electrical fields in the gate oxide regions. Such stress voltages can sometimes be caused by improper testing methods. However, very likely sources are random electrical charges. Possible damage from such static charges can be avoided by implementing the following handling procedures:

- a. All package leads should be shorted together whenever the device is handled or stored. The devices are shipped this way.*
- b. Personnel handling CMOS devices should wear anti-static clothing and be electrically grounded when handling packaged items. This is a standard procedure on CMOS assembly lines.*
- c. Your equipment, which comes in contact with finished units, should be properly grounded to prevent random voltage spikes.*

This section describes the general techniques for maintenance of timing equipment. Special maintenance information, if required, is included with the option descriptions.

5.1 TOOLS AND TEST EQUIPMENT REQUIRED

No tools or equipment are supplied with this unit. The following is a list of equipment needed for maintenance and adjustment of the TM7000 TymMachine TCG/T.

- a. Dual Trace Oscilloscope, Tektronix 2247A or equivalent. This Oscilloscope is a 100MHz bandwidth Oscilloscope with a Frequency Counter and Timer.
- b. Digital Multimeter, Fluke 8010A or equivalent. This instrument should measure AC voltages up to 750 Volts, DC Volts up to 1000 Volts and Ohms up to 20 Megohms.
- c. Insulated Tuning Tool for use in adjusting potentiometers and oscillators.
- d. Screw Drivers, Flat Blade and Philips, used to remove/reinstall top covers and bolt-in assemblies.

5.2 PREVENTATIVE MAINTENANCE

This instrument consists of solid-state electronic circuits, which require very little attention. In general, the equipment will meet its performance requirements without periodic adjustments.

The equipment should be cleaned periodically to prevent accumulations of dust for proper cooling of the equipment.

- a. Wipe the external surfaces of the instrument with a soft damp cloth to remove dirt, fingerprints, and any other foreign material.

***** CAUTION *****

The polarization plate attached to the surface of the LCD Display panel is easily scratched, and must be handled with care.

To clean the display surface, dampen a soft cloth slightly with clean water and wipe gently. Do not use organic solvents such as alcohol.

- b. To check the inside of the unit for excessive dust or foreign matter, first remove the AC Power and then remove the top cover.
- c. If the internal component surfaces and/or components have an excessive amount of dust deposited on them, use a soft brush or low pressure stream of air to remove any foreign material.

***** CAUTION *****

Do not clean PC boards or small internal components with a stiff brush or solvents since damage to the circuits may result. A high powered vacuum device cleaner should not be used on small components.

- d. When cleaning is completed replace the cover and reconnect the power. Check the operation of the unit.

5.3 TROUBLESHOOTING

If at any time the unit fails to operate or operates intermittently, it is a good idea to remove the top cover and look for any visible problems or damage. Make sure all cables are securely connected. Insure all integrated circuits are mounted into their sockets where applicable. Look for damaged components.

***** CAUTION *****

Before removing the top and/or bottom covers, remove the AC Power input. If trouble shooting is necessary with power applied, take precautions near the right rear of the unit, as viewed from the front, as the primary AC power is exposed.

Because the design of the unit utilizes LSI (Large Scale Integrated) circuits, and is Microprocessor based, much of the operation is controlled by firmware/software. There are few user serviceable components.

The TymMachine executes a self-test program when the unit is powered-up. Following are possible symptoms of operational problems and possible causes:

When the user attempts to access an optional assembly and gets the “Selection Not Installed Display”, as shown in Figure 5.3.1, the option is either not available, not properly installed, or has failed and should be replaced.

Selection Not Installed Display

Selected option is not installed.
Call your DATUM representative

Figure 5.3.1

In the event this message is displayed the user should check to see if the Option is installed. If the option is installed, check to be sure the option is plugged into the option assembly connector and is oriented with the component side up.

5.3.1 POWER-UP SELF TEST

Every time power is applied to the unit, a self-test is performed on many circuits within the Generator, Translator and other optional assemblies. If the generator is stopped, the unit will perform the LED test sequentially displaying all zeros through nines. If the unit passes self-test (at power on) but doesn't seem to be working properly, manually resetting the microprocessor is probably all that is necessary. Paragraph 5.3.5 explains the Manual Reset procedure.

5.3.2 GENERATOR (part of STCG Assembly)

When the Generator assembly fails self test, the “Versatile Display Function Menu”, shown in Figure 5.3.2, will not be displayed (assuming power has been off for several seconds). While this test is primarily intended to alert the user to a failed condition which might otherwise go undetected, diagnostics are indicated which may pinpoint the source of the trouble. The unit seconds (far right LED) display is used for diagnostics as follows in Table 5-1: (last indication points to the failure).



Figure 5.3.2

**Table 5-1
Self-Test Fault/Pass Table**

Indication	Test Passed
1	VCOM ORB (U29)
2	VUSR ORA (U13)
3	VCOM ORA (U29)
4	U23
5	LCD DISPLAY

As each test is passed, the number of that test is displayed. “5” will be displayed momentarily at the end of a successful test.

For example, if the Self-Test failed, and an “4” was displayed, it would indicate that the LCD test failed. (All the tests prior to that passed).

5.3.3 TRANSLATOR (part of STCG Assembly)

Each time a command is sent to the Translator, it must respond or a special “HELP” “TRANSLATOR FAILED” message will be displayed. This does not interfere with the Generator time keeping, so it may be desirable to keep the unit operating until the Translator section can be repaired.

5.3.4 SYSTEM TROUBLES

Table 5-2 lists some system troubles and possible solutions. This, along with the Theory of Operation in Chapter Four of this User’s Guide, can be very helpful.

**Table 5-2
Trouble Symptoms/Solutions**

Symptom	Possible Problem and Solution
LED and LCD Displays do not illuminate at Power-up.	Check internal cabling using Drawing A-TM7000. Check AC Power fuses located in the fuse drawer of the Input Power Module. (Part of Cable Assembly 812587.) If bad replace with 1 Amp 250V Slow Blow 5x20MM Fuses.
AC Input Fuses OK but LED and LCD displays do not illuminate.	Check power supply output voltages on J32 of the STCG Assembly 100007. Disconnect the power supply connector and measure the voltages at the power supply. This will determine if the power supply is defective, or if the unit is loading down the power supply. If bad replace Power Supply. Check for a +5 Volt output at pin 3 of A1, a Three Terminal Regulator. (See Figure 5.3.3 at the end of this table.)
LED and LCD displays illuminate and all Power Supply Voltages are present on STCG Assembly. However, the LED display updates slowly or not at all. (This assumes the generator is started).	Check for presence of a 10MHz signal at the center pin of J30. If no signal is observed, the Internal Oscillator at Y2 or Y3 needs to be replaced. As a check to see if the Internal Oscillator is bad, an External Frequency may be input to rear panel BNC connector J5. See Chapter Three, Section 3.9.
Unit powers up and passes self-test but LCD Display Characters not easily readable.	Try adjusting the LCD Display Intensity (Contrast) control R9.
LCD Display characters illegible.	Perform a Manual Reset. If characters are still bad replace LCD Display.
Unit Powers-Up but does not operate.	Microprocessor may need to be reset. Perform a Manual Reset.

Table 5-2
Trouble Symptoms/Solutions (Continued)

Symptom	Possible Problem and Solution
Unit fails to operate at power up and after Manual Reset performed.	Possible failure or improper installation of an Option Assembly. Remove Option Assembly(s) and perform a Manual Reset. Possible bad LCD Display. LCD Display must respond to Microprocessor to allow unit to operate. Replace LCD Display.
Unit will not Translate or Sync to the Code input at J8.	Possibly wrong input code or filter selected. Check Input Code selected. Possible AGC/Code Stripper problem. Check TP4 for a CMOS level square wave at the rate of the selected Code Input. Check TP3 for a $\emptyset C$ signal. Check the AGC/Stripper circuitry (TP2) if there are no signals at TP4 and TP3.

Table 5-3
J32 Power Connector
Pin Assignments

J32 Pin	Signal
1	+12 Volts
2	+5 Volts
3	+5 Volts
4	Ground
5	Ground
6	-12 Volts

Figure 5.3.3

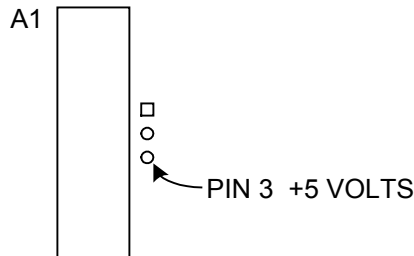

5.3.5 MANUAL SYSTEM RESET

If the unit passes self-test (at power on) but doesn't seem to be working properly, manually resetting the microprocessor is probably all that is necessary.

***** CAUTION *****

A Manual Reset will stop the Generator and set most user selectable parameters to default values, necessitating re-entry of set-up information.

To perform a Manual System Reset proceed as follows:

- a. Set the units POWER Switch to OFF.
- b. Depress and hold the SELECT switch adjacent to the PREV switch.
- c. Apply power to the unit and release the select switch as soon as the LED display updates.

5.4 REPLACING AN OPTION MODULE

***** CAUTION *****

CMOS circuitry is used extensively in this unit. Exercise appropriate precautions.

Plug-in options can be readily replaced by removing the power source, removing the option, and replacing it if a spare is available. If an option has failed and cannot be replaced, it should nonetheless be removed (with power turned OFF) to prevent possible effects on the rest of the unit.

The following procedure should be adhered to when removing and reinstalling any option card assembly: Refer to Figure 5-2:

- a. Disconnect power from the TymMachine.
- b. Remove any applicable I/O cables.
- c. Remove the six screws that secure the Rear Panel Option Plate to the Chassis. (i.e. the Option Area – Locations M1 through M4).
- d. Remove the defective option assembly. Repair the assembly and replace it or install a new/spare option card after having first verified all the settings and correct configuration. Refer to the Option Description supplied with the card or furnished in the back of this User's Guide.

CHAPTER FIVE

- e. Insert the option assembly into the selected option slot, being careful that the components are on the upper side of the assembly.
- f. Reattach the Rear Panel Option Plate to the Chassis.
- g. Attach any applicable I/O cables, and apply power to the unit.

Figure 5-2

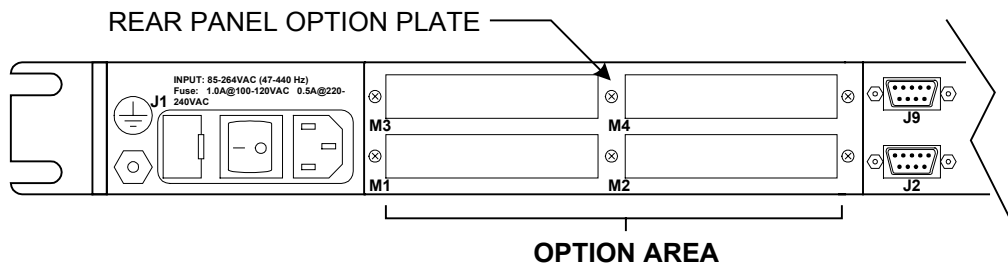

Replacement of a bolt-in module (STCG, Display Assembly etc.) can be easily accomplished using the following procedure:

- a. Removing power.
- b. Remove the top cover.
- c. Remove cables attached to the module
- d. Remove the screws or nuts, which secure the module to the chassis.

Modules are replaced by reversing the above procedure. Take special care that all cables are correctly connected, or the unit could be damaged.

5.5 ADJUSTMENTS AND TESTS

The following are adjustment and tests used to check adjustments if applicable. The adjustments have been divided into two categories – Those that are routine adjustments, and those adjustments that should only be performed if applicable circuit parts have been replaced.

***** CAUTION *****

The Top Cover of the TymMachine must be removed to make the following adjustments and tests. This exposes a potential safety hazard in the Power Supply area which is located in the right rear corner of the unit as viewed from the front.

5.5.1 OSCILLATOR ADJUSTMENT (Routine Adjustment)

The following paragraphs are to be used in the adjustment of the various oscillators, which may be used in the TymMachine:

A. STANDARD TCXO OSCILLATOR ADJUSTMENT (location Y2 if applicable):

- a. If the generator isn't running, start it. From the Versatile Display function menu select GENERATOR/OPERATE/START.
- b. Sync one channel of an oscilloscope with a pulse rate output from the unit (preferably 1KPPS found in rear panel connector J3 pin 1.)
- c. Connect a stable oscillator of known frequency to the other input channel of the oscilloscope. Note that the stability and accuracy of the External Oscillator must be better than that of the Internal Oscillator.
- d. Make sure that the Sync Gen is disabled. From the Generator control menu (the menu containing Stop, Start etc. as in Step c above) select SYNC/SYNC-GEN/DISABLE.
- e. Adjust the COARSE oscillator adjustment (with an insulated tuning tool) for the most stable display possible. It should not drift either left or right.

B. OPTIONAL OVEN OSCILLATOR ADJUSTMENT (location Y3 if applicable):

- a. If the generator isn't running, start it. From the Versatile Display function menu select GENERATOR/OPERATE/START.
- b. Remove the dust cap screw from the side of oscillator.
- c. Sync one channel of an oscilloscope with a pulse rate output from the unit (preferably 1KPPS found in rear panel connector J3 pin 1.)
- d. Connect a stable oscillator of known frequency to the other input of the oscilloscope. Note that the stability and accuracy of the external oscillator must be better than that of the internal oscillator.
- e. Make sure that the Sync Gen is disabled. From the Generator control menu (the menu containing Stop, Start etc. as in Step c above) select SYNC/SYNC-GEN/DISABLE.
- f. Adjust the COARSE oscillator adjustment (with an insulated tuning tool) for the most stable display possible. It should not drift either left or right.

- g. Reinstall the dust cap screw on the side of oscillator.

5.5.2 FREQUENCY OUTPUT AMPLITUDE ADJUSTMENT (Routine Adjustment)

- a. Connect the Frequency Output BNC Connector, J5, to an Oscilloscope terminating it with 50 Ohms and observe a 10 MHz Sine Wave. See Chapter Three, Section 3.10.
- b. Adjust the output for an amplitude of 2.8 ± 0.2 Volts Peak-to-Peak into a 50 Ohm load using Potentiometer R184, labeled "OSC LEVEL".

5.5.3 CODE OUTPUT ADJUSTMENTS (Routine Adjustments)

Following are the adjustments for the Modulated Serial Time Code output:

- a. Connect the rear panel BNC connector J10, the IRIG B Modulated Serial Time Code Output, to an oscilloscope terminated with 50 Ohms.
- b. Phase Adjustment: While observing the code output on an oscilloscope, adjust R100, labeled "PHASE" for minimum discontinuity at the modulation points of the code. This is the point where the sine wave goes from a "Mark" amplitude to a "Space" near the zero crossing point.
- c. Amplitude Adjustment: While observing the code output on an oscilloscope, adjust R101, labeled "LEVEL", for a 3 ± 0.2 Volts peak-to-peak or desired amplitude.
- d. Modulation Ratio Adjustment: While observing the code output, adjust R86, labeled "RATIO" for a 3:1 or other desired ratio of the "Mark" amplitude to the "Space" amplitude.

5.5.4 LCD CONTRAST ADJUSTMENT (Routine Adjustment)

If the LCD will be consistently viewed from a higher or lower angle than normal, R9 (Near connector J103) on the STCG, may be adjusted to improve contrast. Keep in mind that improving the contrast from one angle may make it worse from another. Seek an optimum compromise.

5.5.5 LOS THRESHOLD ADJUSTMENT (Routine Adjustment)

- a. Perform a Master Reset on the TM7000 (see Step 5.1.1).
- b. Connect J3 Pin 11 (LOS) to an Oscilloscope, using J3 Pin 9 as the return. Observe this signal to be at a true (Hi) level with no Code Input to rear panel BNC connector J8.
- c. Connect an adjustable amplitude IRIG B modulated Serial Time Code to an oscilloscope and to J8, the Code Input of the TM7000.
- d. Adjust the IRIG B Serial Time Code input for a level of 1 Volt peak-to-peak or other desired level.
- e. The loss of signal (LOS) threshold is adjustable with the “THOLD” potentiometer (R132), located near the left rear corner of the STCG Assembly. Starting with the potentiometer fully CCW, slowly adjust CW until the signal at J3 Pin 11, LOS, goes true, then turn CCW until LOS goes false.

5.5.6 MULTI-ENCODER CODE OUTPUT ADJUSTMENTS (Routine Adjustments)

- a. From the “Select VERSATILE DISPLAY Function” menu, select sequentially, GENERATOR/SET-UP/OUTPUTS/RE/GEN.
- b. Select “B” (or other desired code) by pressing the switch directly below it and observe it to blink.
- c. Connect the rear panel BNC connector J12, the Multi-Encoder Modulated Serial Time Code Output, to an oscilloscope terminated with 50 Ohms and observe the Modulated Serial Time Code.
- d. Amplitude Adjustment: While observing the code output on an oscilloscope, adjust R20, labeled “AMP”, for 3 volts peak-to-peak (or other desired amplitude) into a 50 Ohm load.
- e. Modulation Ratio Adjustment: While observing the code output, adjust R21, labeled “RATIO” for the desired ratio of the “Mark” amplitude to the “Space” amplitude.

5.5.7 PLL (CARRIER FILTER) ADJUSTMENTS (See Caution Note below)

To adjust the PLL circuitry located on the STCG, proceed as follows:

***** CAUTION *****

This adjustment is performed in the factory and should only be required following replacement of parts in the immediate circuit. Incorrect adjustment will render the TymMachine translator unreliable or inoperable.

- a. From the “Select VERSATILE DISPLAY Function” menu, select sequentially, TRANSLATOR/YES/NEXT/IRIG/B.
- b. While the “Translating” screen is shown, select “IN” under “FILTER” by pressing a switch under “IN” and observe the “FILTER” screen to appear.
- c. Under “CARRIER FILTER” Select “in” by pressing a switch below it and observe it now to be capitalized, indicating the Carrier Filter is IN.
- d. Press the “NEXT” switch and observe the “PLAY/SEARCH SPEED RATIO” screen to appear.
- e. The “PLAY SPEED RATIO” must be set to “1:1”. If it is not set to “1:1”, it may be set to “1:1” by pressing a switch under “slower” or “faster” until “1:1” is shown.
- f. Connect an IRIG B 1:1 Modulated Serial Time Code input to rear panel BNC connector J8, the Code Input BNC.
- g. The adjustment potentiometers R96, R97, and R88 are located near U40. Adjust R96, labeled “RANGE 1” fully Clockwise.
- h. Connect J3 Pin 5 to the Universal Counter using J3 Pin 9 as the return and set up the Universal Counter to read Frequency. The Counter shall display a frequency of 1KHz \pm 2Hz.
- i. Temporarily ground Pin 9 of IC U37 and adjust Potentiometer R97, labeled “FREQB” for an output frequency at J3 Pin 9 of 960Hz \pm 5Hz as read on the Universal Counter.
- j. Remove the ground from Pin 9 of IC U37 and temporarily connect Pin 9 of IC U37 to +5 Volts and adjust Potentiometer R96, labeled “RANGE1” for a frequency of 1080Hz \pm 5Hz as read on the Universal Counter.

- k. Remove the +5 Volts from Pin 9 of IC U37. Activate the NEXT switch 2 times, and then select YES.
- l. Select “TRANSLATOR” from the “Select VERSATILE DISPLAY function” screen by pressing any switch below “TRANSLATE”. The “WARNING” screen will appear.
- m. Select “YES” from the “WARNING” screen by pressing the switch below “YES” and observe the “Set-up Translator” screen to appear.
- n. Press the “NEXT” switch while the “Set-up Translator” screen is shown on the LCD Display and observe the “Select Desired Code Family” screen to appear.
- o. Select “IRIG” by pressing a switch below “IRIG” and observe the “Select Desired IRIG Code” screen to appear.
- p. Press the switch directly below “A”, selecting IRIG A, and observe the “A” to blink.
- q. Press the “NEXT” switch and observe the “Translating” screen to appear showing Translating IRIG A.
- r. Connect an IRIG A 1:1 Modulated Serial Time Code input to rear panel BNC connector J8, the Code Input BNC.
- s. Connect the Ground lead of the Digital Voltmeter to the COM2 Test Point, which is ground.
- t. Connect the Positive lead of the Digital Voltmeter to Pin 9 of IC U37.
- u. Adjust Potentiometer R88, labeled “FREQA”, to produce 2 Volts ± 0.1 Volt at Pin 9 of IC U37.

5.5.7 PLL (CARRIER FILTER) TESTS

- a. Set up the TM7000 to translate IRIG B as previously described ,and proceed to the “FILTERS” screen as previously described.
- b. Set both the Envelope and Carrier Filters to ON by pressing the switch below “IN” under Envelope and Carrier and “coast” should not to be in capital letters indicating coast is OFF.
- c. Connect a 1:1 IRIG B source to rear panel connector J8 of the TM7000. Momentarily (less than 1 second) remove and reconnect the IRIB B input from J2 and observe the unit continues to update. Note that if you remove the input for more than a few seconds, the TM7000 update will stop.

CHAPTER FIVE

- d. Set “coast” to ON by pressing any switch under “coast” observing that it becomes capital letters.
- e. Remove the IRIG B input from J8 and observe that the TM7000 continues to update. It should continue to update indefinitely.

5.6 FIRMWARE UPGRADING

This section provides installation instructions for upgrading the firmware of the TymMachine. Upgrading is accomplished by replacing an EPROM in the STCG with that provided. To replace the original EPROM, proceed as follows:

- a. Switch the TymMachine off and remove the power cable.
- b. Remove fifteen screws in the top cover, and then remove the top cover.
- c. The EPROM provided is marked with a two letter prefix (DT), followed by five digits, and then a revision letter. Example: DT10024A
- d. Carefully remove the existing EPROM in location U21 on the STCG (Synchronized Time Code Generator) Assembly and install the new one. Be careful to observe orientation when installing the new EPROM in the socket.
- e. Replace the top cover and install the fifteen screws.
- f. Re-connect the power cable.
- g. Perform a manual reset by depressing and holding the SELECT switch adjacent to the PREV switch while switching the power on.
- h. Turn power on, and release the select switch as soon as the LED updates. The unit may now be returned to service, or if new features have been incorporated, the unit may be used or tested as described in this TymMachine User’s Guide.

APPENDIX A

OPTION DESCRIPTIONS

TM Option 02A Tape Search With AUX (DIP Relays) Assembly 20138-1

1.0 INTRODUCTION

This assembly is used to provide the electrical interface between the TymMachine 7000 and a Tape Recorder/Reproducer. The interface consists of relay contacts, which may be interconnected by the user to control a variety of Recorder/Reproducers. The -1 Assembly includes Tape Speed Control Relays.

1.1 INSTALLATION

This assembly may be plugged into any available double-wide option position. Remove power from the TM7000. If necessary, remove a card guide to create a double-wide position by removing the screw which holds it from inside the unit. Plug this assembly into any available option slot in the rear of the chassis, being careful that components are on the upper side. Interconnect to the recorder/reproducer. Apply power.

1.2 SPECIFICATIONS

Momentary closures are about 250 milliseconds. To provide overlap with forward and reverse, RECORD is about 330 milliseconds. When FAST and a direction are output, the FIRST is about 250 milliseconds, and the last is about 330 milliseconds, starting simultaneously. Timing is altered slightly when modified to operate with Models 90 and 97. FAST 2 is a continuous closure. Specifications for the relay contacts are as shown in Table 1, Relay Contact Specifications.

TABLE 1
Relay Contact Specifications

The Voltage rating for all relay contacts is 100VDC.

Function	Contact Arrangement	Contact Current
FWD	2A	.5A
REV	2A	.5A
STOP	1C	.25A
FAST	1C	.25A
FAST 2	1C	.25A
ALL SPEEDS (Speed control is provided by the -1 assembly.)	1A	.5A
EARLY	1C	.25A
INTERVAL	1C	.25A

Start pulse, stop pulse, and interval DC are TTL/CMOS compatible 4mA sink. Pulses are 5 ± 2 microseconds wide.

APPENDIX A

1.3 MAINTENANCE

No routine maintenance is required.

1.4 INTERCONNECTION

Connector pin out information For J1 is provided in Figures 2 and 3. J2, Auxiliary Outputs, are shown in Table 2 below.

Table 2
J2 Auxiliary Outputs
20 Pin Flat Cable Type

Pin Number	Function
1	Stop Pulse-Negative
2	Stop Pulse-Positive
3	GND
4	Stop Pulse-Positive
5	Stop Pulse-Negative
6	Interval DC
7	GND
8	Early N-C
9	Early C
10	Early N-O
11	Interval N-C
12	Interval C
13	Interval N-O
14	
15	GND
16	
17	GND
18	
19	GND
20	

REAR VIEW OF CARD-EDGE CONNECTOR

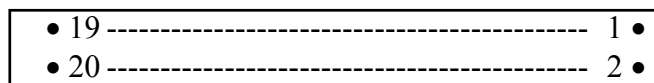

Figure1

See Figure 2, Tape Control Relays, for Tape Search Control Relay connections when using the 20138 assembly.

See Figures 2, Tape Control Relays and Figure 3, Tape Speed Relay connections when using the 20138-1 assembly.

Note: J1 is a 37 Pin D Male type connector.

Figure 2

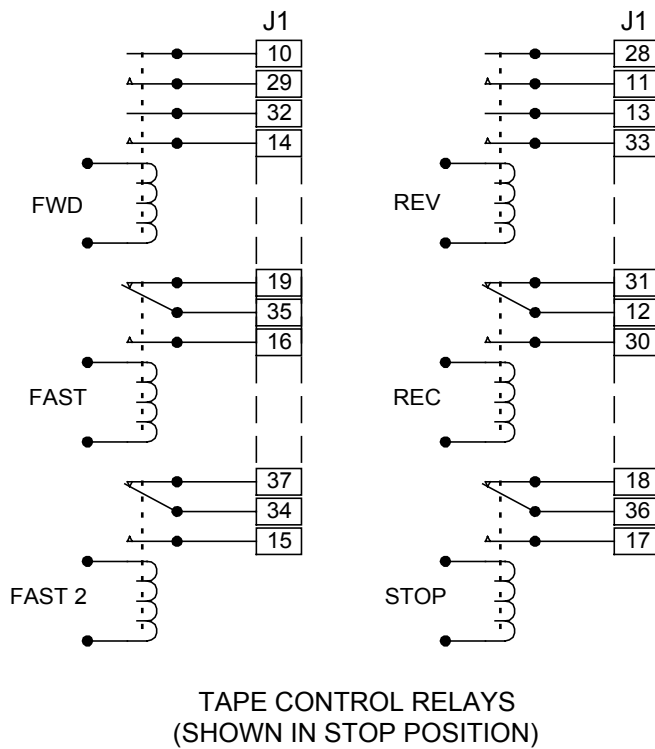
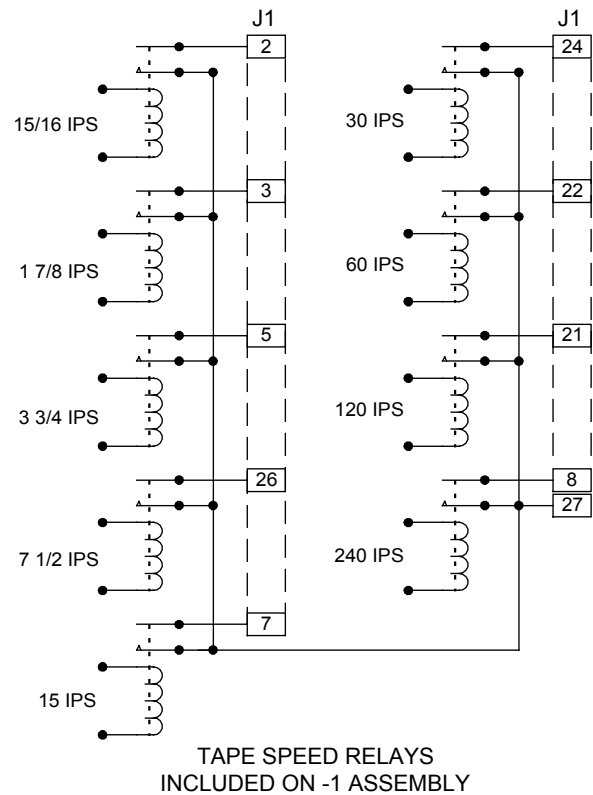

Figure 3



1.5 OPERATION*

Operation and set-up for Transport parameters are described in this Option after paragraph heading "Using Tape Search Menus". The Stop Relay is configured to output a stop closure when power fails, and at power-up. This is a continuous closure, even if "momentary" has been selected. It may be overcome by entering the MAN-S or AUTO-S menu, and issuing a STOP command.

* If the unit will be used to control a Model 90 or 97 Tape Transport, remove R9 and R15 before the installation.

1.6 USING TAPE SEARCH MENUS

Note: The Translator must be setup for the code to be translated and filters to be used with this option. See the *TymMachine 7000 User's Guide for Translator Set-Up*.

The following section describes the use of the TAPE SEARCH menus.

APPENDIX A

The TAPE SEARCH menu is selected from the Select VERSATILE DISPLAY Function Menu shown in Figure 4.

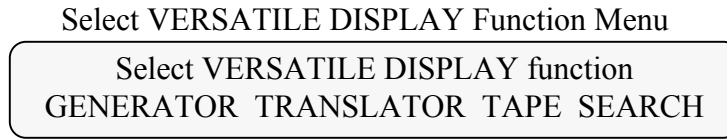

Figure 4

Pressing any switch below TAPE SEARCH will cause the Warning Message shown in Figure 5 to be displayed on the TM7000 LCD Display.

In some instances, a menu selection requires a mode change in the unit. The following Warning Message shown in Figure 5 will appear to remind the user of a mode change:

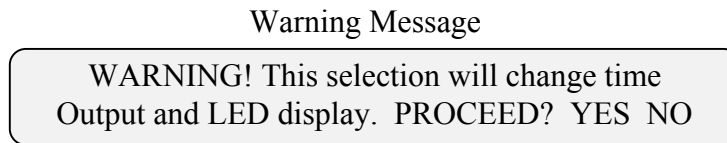

Figure 5

The unit will only proceed to a different mode if YES is selected from this menu. If NO is selected, the unit will revert to the previous menu and the mode remains intact. If YES is selected the LCD Display will change to the Tape Search Mode Select Menu as shown in Figure 6.

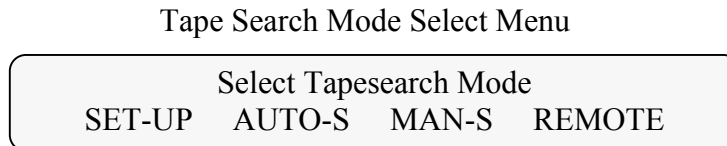

Figure 6

Selecting SET-UP from this menu by pressing a switch under SET-UP will cause the TM7000 LCD Display screen to change to the SET-UP Menu shown in Figure 7.

Pressing a switch under AUTO-S will change the LCD Display to the Interval Screen shown in Figure 13. The Interval Screen is followed by the Auto Search Operating Menu Figure 14.

When a switch under MAN-S is depressed the Manual Search Operating Menu, Figure 16 will appear on the LCD Display.

The REMOTE Menu will be displayed if the REMOTE Option is installed.

Pressing the NEXT or PREV switch while the Tape Search Mode Select Menu is displayed will result in the Warning Message display, Figure 5 being displayed on the LCD Display.

1.6.1 TAPE SEARCH SET-UP MENU

The Tape Search Set-Up Menu screen is shown in Figure 7.

This menu is used to access menus used to set-up the Tape Search parameters. If set-up has been done previously, go directly to the Auto-Search (AUTO-S) or Manual-Search (MAN-S) menu.

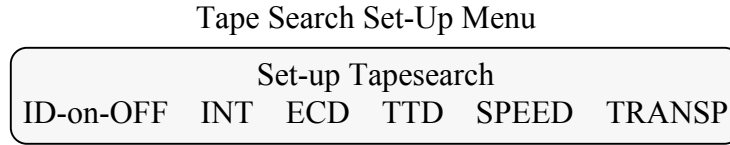

Figure 7

1.6.2 ID (DAYS)

Selecting “ON” or “OFF” after ID determines whether intervals will be searched for ID Number (days only 0 to 999) or Time-of-Year, milliseconds through hundreds of days.

When “ON” is in upper case letters intervals will be searched for ID Number (days only 0 to 999) and when “OFF” is in upper case letters Time-of-Year, millisecond through hundreds of days, intervals will be searched.

1.6.3 INT (SEARCH INTERVALS)

Selecting INT, using the switch under INT, results in the Interval Menu Figure 8 being displayed on the LCD Display.

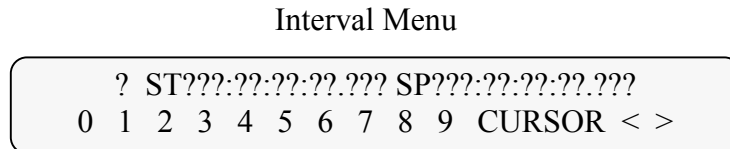

Figure 8

This menu is used for setting up the Tape Search intervals. Up to ten intervals, numbered zero through nine may be preset. When this menu first appears, the cursor is at the interval number, in the top left corner. The interval may be changed, by entering a number zero through nine. When the interval number has been selected, Start (ST) and Stop (SP) times may be entered.

The easiest way to do this is to move the cursor right, causing it to move to hundreds-of-days Start Time. Start time (ST) can be entered hundreds-of-days, tens-of-days etc. from left to right, with the cursor automatically stepping as each digit is entered. When milliseconds of Start Time is entered, the cursor will move to Stop Time (SP) which can be entered in the same fashion. Digits can be skipped over without modification by use of the cursor right (>) or left (<) switches.

APPENDIX A

Subsequent intervals can be entered using the same procedures, after changing the interval number. It is not necessary to enter intervals unless they will be searched. If the Single Cycle-Multiple feature will be used, interval numbers must be sequential starting with interval zero. It is the operator's responsibility to enter only valid times into the intervals. When using a code without days content, be sure that the days portion of the interval (s) is set to zero.

Pressing the NEXT or PREV exits this menu to the Tape Search Set-Up Menu, Figure 7.

1.6.4 ECD (EARLY CLOSURE DELAY)

When the switch directly below ECD is pressed the LCD Display will change from that shown in Figure 7 to the display shown in Figure 9, the Early Closure Delay Menu.

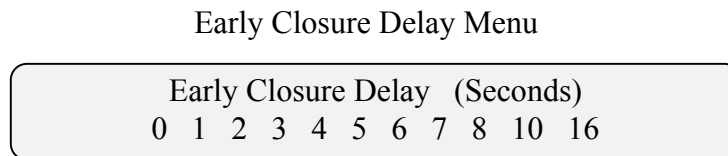

Figure 9

This menu is used in conjunction with the Auto-Search (AUTO-S) mode. Early Closure Delay (ECD) positions the tape a selected number of real time seconds below the Start Time (ST) when an interval is searched for. Early closure outputs may be then used to ready external equipment prior to the beginning of an interval.

The amount of Early Closure Delay (ECD) is selected by pressing the switch under the desired number of real time seconds. The selected delay is indicated by the cursor. ECD should be adequate to enable translation before reaching a Start Time so that the beginning of the interval will be recognized.

Pressing either NEXT or PREV exits this menu to the Tape Search Set-Up Menu, Figure 7.

1.6.5 TTD (TAPE TRANSPORT DELAY)

The Tape Transport Delay Menu, Figure 10, is accessed by pressing the switch below TTD when the Tape Search Set-Up Menu, Figure 7, is displayed on the LCD Display.

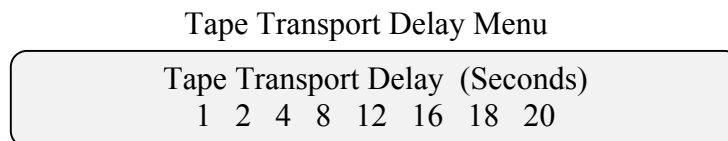

Figure 10

This menu is used to select the Tape Transport Delay (TTD). TTD is required for transports, which must come to a full stop before another command can be issued. TTD is a real-time delay between the issuance of a Stop command and the following command. TTD only functions in the Auto-Search (AUTO-S) modes. The selected TTD is indicated by the cursor. The Tape Transport Delay may be changed, by pressing the switch below the desired delay.

Pressing the NEXT or PREV exits this menu to the Tape Search Set-Up Menu, Figure 7.

1.6.6 SPEED (TAPE PLAYBACK SPEED) (OPTIONAL)

Access to the Playback Speed Select Menu, Figure 11, is gained by pressing the switch below SPEED while Tape Search Set-Up Menu, Figure 7, is displayed.

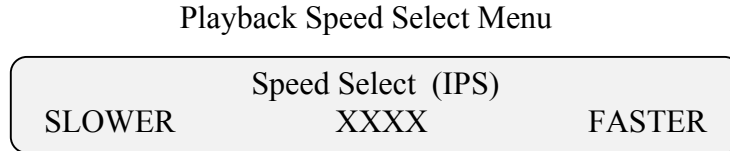

Figure 11

Tape playback speeds may be selected from 15/16-240 IPS. The selected speed is displayed between SLOWER and FASTER. It may be increased or decreased by using the switches below SLOWER or FASTER switches.

NEXT or PREV exits this menu to the Tape Search Set-Up Menu.

1.6.7 TRANSP (Tape Transport Set-Up)

The Set-Up Transport Menu, Figure 12, is displayed on the LCD Display when a switch below TRANSP is pressed while the Tape Search Mode Select Menu is shown.

This menu is used to set-up parameters unique to the Tape Transport.

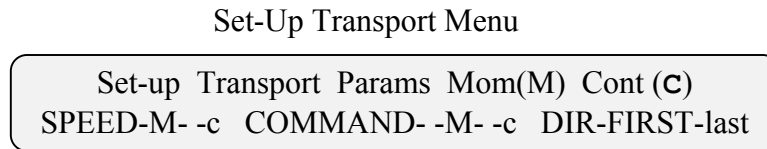

Figure 12

The Play Speed command can be selected momentary or continuous by using the switches under SPEED-M- -c. "M" will be in upper case letters when momentary is selected and "c" will be in upper case letters if continuous is selected.

The Command can be selected momentary or continuous by using the switches under COMMAND- -M- -c. "M" will be in upper case letters when momentary is selected and "c" will be in upper case letters if continuous is selected.

The timing of the direction (forward or reverse) with respect to the motion (fast) command may be first or last using the switches under DIR-FIRST-last. In each of these cases, the operator selection is capitalized. Direction and motion commands overlap in time. NEXT or PREV exits this menu to the Tape Search Set-Up Menu, Figure 7.

APPENDIX A

1.7 AUTO-S (AUTO SEARCH OPERATION)

The following menus are associated with Automatic Tape Search.

Pressing a switch under AUTO-S while the Tape Search Set-Up Menu, Figure 7, is displayed on the LCD causes the Interval Screen, Figure 13, to be displayed.

One of the Auto-Search modes involves automatic single-cycling through multiple intervals. This menu is used to enter or verify the number of the last interval to be cycled. The selected last interval number is displayed at the far right.

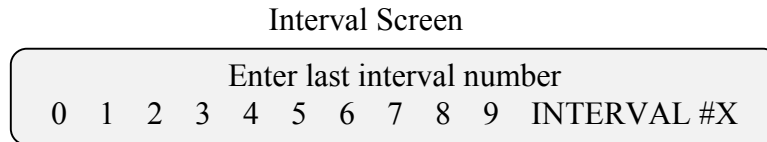

Figure 13

Pressing the NEXT or PREV switch while the Interval Screen is displayed results in the LCD Display changing to the Auto Search Operating Menu, Figure 14.

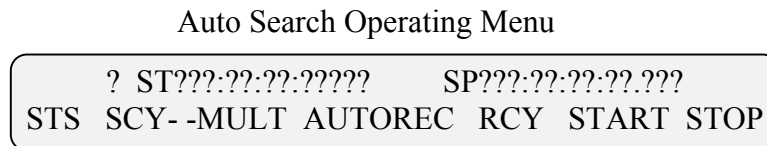

Figure 14

This is the Auto Search Operating Menu. The Interval Number (top left) and Start (ST) and Stop (SP) times are displayed on the top line.

Operator controls are displayed on the bottom line. Pushing the switch below a command initiates that command. The current tape position is automatically considered in determining whether to go forward or reverse when searching, so if the tape has been changed, it is advisable to START (play) for a few seconds to tell the TM7000 where the tape is located.

1.7.1 STS (SEARCH TO START)

This function causes the transport to travel at search speed to a position preceding the Start Time by the amount of ECD. The transport will go fast forward, if necessary, then fast reverse below the Start Time, then stop. Activating START at this time puts the transport into a play forward. Play will continue to Stop Time, when a stop command will be issued.

1.7.2 SCY (SINGLE CYCLE)

This is identical to STS except when the search cycle ends, a start command is automatically given. To select this mode, push the SCY switch. SCY- - MULT (single cycle-multiple) is like a single cycle except it performs a single cycle on all intervals from zero through the selected last interval.

1.7.3 SCY - - MULTI (SINGLE CYCLE-MULTIPLE)

This always begins with interval zero. To select this mode, push the SCY-MULT switch.

SCY- - MULT (single cycle-multiple) is like a single cycle except it performs a single cycle on all intervals from zero through the selected last interval.

1.7.4 AUTOREC (AUTO RECORD)

Used in conjunction with a real time code input. It is used to initiate forward record at interval Start Time and stop the recorder at interval Stop Time.

1.7.5 RCY (RECYCLE)

This is like SCY except at the end of SCY another SCY is begun. To stop RCY, use the STOP switch.

1.7.6 START

START is for use following STS.

1.7.7 STOP

STOP may be used at any time during any cycle to stop the transport. Stop should be used when changing modes.

1.8 MAN-S (Manual Search Operation)

The following menu is associated with Manual Tape Search operation.

Pressing a switch under MAN-S while the Tape Search Set-Up Menu, Figure 7, is displayed on the LCD causes the Manual Search Operating Menu, Figure 15, to be displayed.

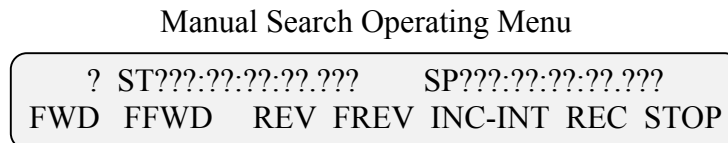

Figure 15

APPENDIX A

This menu is used for manual control of the tape deck and interval section. Interval selection is accomplished by successively pressing the INC-INT switch. The interval number indicated in the top left corner of the menu will increment from zero through nine, then to zero. The selected start (ST) and stop (SP) times corresponding to the selected interval are also displayed. When an interval has not been preset, question marks are displayed. Do not attempt to search an interval with any question marks present. Once entered, intervals are retained through power outages. FWD and FFWD are used to play and search in the forward direction respectively. REV and FREV are used to play and search in the reverse direction respectively. REC followed by a direction command (FWD or REV) will initiate recording in the selected direction. STOP is used to stop motion. A stop command is issued when this menu is exited.

**TM Option 04B Fast Parallel Outputs (Parallel BCD Outputs)
F/R (Forward/Reverse) Assembly 21059**

1.0 INTRODUCTION

This assembly is used to provide a BCD time word for use by equipment external to the TymMachine 7000. It uses a phase-locked-loop to generate a 100kHz clock from the input code carrier. This provides hundredths-milliseconds output resolution over a wide range of input code rates.

1.1 INSTALLATION

This assembly may be plugged into any available option position. Remove power from the TM7000. Plug this assembly into the TM, being careful that components are on the top side. Interconnect to the desired destination equipment. Apply power.

1.2 OPERATION

Operation of this option requires the user to select the speed-up ratio of the input code using the translator envelope filter select (when using tape search, select both search and play speeds). Selection of the output automatically follows the operating mode so that the time displayed on the PTS LED is output in the parallel word unless a forcing option is used. See E1, E2, E3.

1.3 SPECIFICATIONS

Output drivers are 74HC type (TTL compatible). Data lines can sink 4mA.

1.3.1 TIME WORD

BCD time-of year. Hundreds-of-days through hundredths-of-milliseconds for generated or translated time.

Outputs are valid at 1x only for generated time. See Table One for translated time.

Table One

Code	Speed Range	
	<i>Forward</i>	<i>Reverse</i>
IRIG G	1:1 - 4:1	NONE
IRIG A	1:1 - 32:1	1:1 - 4:1
IRIG B	1:1 - 64:1	1:1 - 16:1
NASA 36	1:1 - 64:1	1:1 - 16:1
2137	1:1 - 64:1	1:1 - 16:1
ANGSQ	1:1 - 64:1	1:1 - 16:1
1892	1:1 - 64:1	1:1 - 16:1
XR3 (250Hz)	1:1 - 64:1	1:1 - 16:1

APPENDIX A

1.3.2 LOS

Loss of Signal. Specifications and adjustments procedures may be found in the basic manual. Only valid for translatable code, forward 1:1.

1.3.3 FRZ

Freeze. A ground true signal which prevents data update while active (low). 100 nanoseconds after freeze is initiated, the data is static. 11 microseconds after freeze is removed, the data will again start updating.

1.3.4 ERR

Error. Signifies that translated time and input code time are different (only valid in forward direction at real-time, otherwise high).

1.3.5 ENOUT

Enable Output. A ground true input which enables the output drivers. If driven by an open collector output from the destination equipment, such equipment will not load this option when powered down. This input may be grounded at J1.

1.3.6 SAMPLE

A pulse which indicates validity of time. May be used to clock external equipment. The pulse may be inverted by installing a jumper between E4 and E5 (E5-E6 is provided for storage). The pulse rate is selectable from 1pps-100Kpps. See Table Three.

1.3.7 JUMPERS E1, E2, E3

Placing a jumper from E1 to E2 forces output of generated time. Placing a jumper from E2 to E3 forces output of translated time. Without a jumper, time follows the LED display.

Output connector is 62 pin micro-miniature “D” type. See Table Two for signal connections.

Table Three
Sample Time Rate Selection

Desired Rate	Required Jumper
1 pps	E7-E8
10 pps	E9-E10
100 pps	E11-E12
1K pps	E13-E14
10K pps	E15-E16
100K pps	E17-E18

Table Two

Pin	Signal	Pin	Signal
1	GND	32	US2
2	GND	33	US1
3	SPARE	34	tS8
4	HD2	35	tS4
5	HD1	36	tS2
6	TD8	37	tS1
7	TD4	38	hS8
8	TD2	39	hS4
9	TD1	40	hS2
10	UD8	41	hS1
11	UD4	42	mS8
12	UD2	43	mS4
13	UD1	44	mS2
14	TH2	45	mS1
15	TH1	46	tmS8
16	UH8	47	tmS4
17	UH4	48	tmS2
18	UH2	49	tmS1
19	UH1	50	hmS8
20	TM4	51	hmS4
21	TM2	52	hmS2
22	TM1	53	hmS1
23	UM8	54	SAMPLE
24	UM4	55	ERR
25	UM2	56	LOS
26	UM1	57	N/C
27	TS4	58	N/C
28	TS2	59	FRZ
29	TS1	60	ENOUT
30	US8	61	GND
31	US4	62	GND

TM OPTION 07A RS-232 INTERFACE ASSEMBLY 21034-1**1.0 INTRODUCTION**

This plug-in module is designed in accordance with EIA RS-232C specification and is used to provide an electrical interface between the TymMachine 7000 (TM7000) and the RS-232 serial interface. This document provides the user with information to configure this plug-in module.

1.1 GENERAL DESCRIPTION

This module can be divided into two sections: Time extraction and RS-232 communication. The RS-232 communication portion will be the main focus of this document. The time extraction portion of this module is invisible to the user. The time is updated in this module every millisecond unless the module is sending a time message. It is suggested that the user read this document in its entirety for a better understanding of the options provided and what they mean.

1.2 TERMINAL TYPE

There are two basic configurations that need to be described before serial communication can be discussed: Data Communication Equipment (DCE) and Data Terminal Equipment (DTE). The major differences between the two configurations are their rules and pin assignments. DTE is designated as the initiator of the commands. DCE is designated as the responder to the commands. This module is capable of three different output configurations:

- RS-232 DCE Configuration (see Figure One)
- RS-232 DTE Configuration (see Figure Two)
- RS-422 DCE Configuration (see Figure Three)

Notice that the following groups of signals are switched between DTE and DCE configurations:

Read Data (RXC)	Transmit Data (TXD)
Character to Send (CTS)	Ready to Send (RTS)
Data Terminal Ready (DTR)	Data Source Ready (DSR)

It is important to remember that most computer RS-232 communication ports are set up in the DTE configuration, which would require that this module be configured as DCE. The module can be set to either DTE or DCE configuration by moving box pin jumpers on connector J3. The DCE configuration is selected when the box pin jumpers are across columns A and B. The DTE configuration is selected when the box pin jumpers are across columns B and C. This provides the user the option of using an existing cable that has its pins switched (also known as a “null modem” cable) or a cable that is pin-to-pin.

1.3 HANDSHAKING

1.3.1 DCE HANDSHAKING

This module is expecting at least two signals from the user's equipment: DTR and RTS. A third possibility would be TXD and it would only be used in the asynchronous mode. When the DTR signal is not active, the DSR and CTS signals will both be inactive and this module will not send any time messages. When the DTR signal goes active, the DSR and CTS signals will both go active. A time message will be transmitted only when both DTR and RTS are both active. If RTS goes inactive while a time message output is in progress, the time message output will be paused until RTS returns to active, at which time the time message will resume. A partial message can be cleared by setting DTR inactive.

1.3.2 DTE HANDSHAKING

This module is expecting at least two signals from the user's equipment: DSR and CTS. A third possibility would be RXD and it would only be used in the asynchronous mode. When the DSR signal is not active, the DRT and RTS signals will both be inactive and this module will not send any time messages. When the DSR signal goes active, the DTR and RTS signals will both go active. A time message will be transmitted only with DSR and CTS are both active. If CTS goes inactive while a time message output is in progress, the time message output will be paused until CTS returns to active, at which time the time message will resume. A partial message can be cleared by setting DSR inactive.

1.4 MODE OF OPERATION

There are two modes of operation possible with this module: *Synchronous* (burst), and *asynchronous* (demand/response). The *synchronous* mode provides a time message at regular intervals selected by the user. The *asynchronous* mode outputs a time message upon receipt of a predefined character. The 8 bit image of the demand character is set by the user by means of an 8 bit DIP switch.

1.4.1 SYNCHRONOUS MODE

This module is capable of providing time messages at five different rates:

- Ten messages per second.
- One message per second.
- One message per ten seconds.
- One message per one-hundred seconds.
- One message per 1000 seconds.

1.4.2 ASYNCHRONOUS MODE

When this module is set up in the asynchronous mode the time output rates described in "Synchronous Mode" will be ignored. The user must select an 8 bit character (any hex value from 00 to FF) as a time demand character. The user sends the selected character to this module, which causes a time message to be output in response.

Note: When a switch is set to the "ON" position, the voltage for that line is 0 volts or low. In other words, ON = Binary Zero; OFF = Binary One.

APPENDIX A

1.5 MESSAGE FORMAT

The message format can be divided into several subdivisions:

- ASCII/BCD
- *Baud Rate
- *Stop Bit
- *Parity
- Word Length (ASCII only)
- Preamble
- Postamble (Not selectable in ASCII)
- Quality Indicator

Note: The asterisk (*) before the baud rate, stop bits and parity indicate that when these values are changed the UART needs to be reloaded. There are three ways to load the UART:

- 1) Power down the TM7000 and power it up again.
- 2) Disconnect the RS-232 cable and reconnect it.
- 3) Move SW4-8 to the ON position and then back OFF.

If one of these steps are *not* done the UART *will not* reconfigure to the new settings.

The user should select the appropriate settings for their needs. A brief description of each of the subdivisions follows.

1.5.1 ASCII/BCD FORMAT

When the ASCII format is selected, each byte will be an ASCII character as detailed in Table One and One-A. The last two bytes are always CR and LF. The preamble byte and the two quality bytes are optional. This format is simple to process, since all characters are ASCII, but each digit requires a full byte.

The BCD format packs two digits into each byte as shown in Tables Two and Two-A. The preamble, postamble and quality byte are optional. This format is more difficult to process, since each decimal digit must be masked and extracted from the byte, but the time message can be transmitted faster, since fewer bytes are required.

1.5.2 BAUD RATE

This assembly is capable of generating fifteen baud rates. They are 50, 75, 110, 134.5, 150, 200, 300, 600, 1200, 1800, 2400, 4800, 9600, 19200 and 38400. For the required switch settings for each of the baud rates, please see the main User's Guide.

1.5.3 WORD LENGTH

The word length can be varied in both BCD and ASCII message format. The user can choose between 7 or 8 bits.

*** * * CAUTION * * ***

If the word length is set to 7 bits while using the packed BCD format, the most significant bit of some digits will be lost and an irrational time message will be transmitted. Always select the 8-bit word length when using the packed BCD output format.

1.5.4 STOP BIT

There are three possible settings for the stop bit: 1, 1.5 and 2. The 1.5 setting is used for some old teletype equipment, which does not apply here. Generally, use 1 or 2 stop bits.

1.5.5 PARITY

There are three possible settings for parity: none, odd and even. The settings are valid in both ASCII and BCD message formats. If parity is set to odd or even, then the parity will be added to the output word. For example, if the UART is set to 8 data bits, 1 stop bit and odd parity, then the entire transmitted word is 11 bits in length (1 start bit + 8 data bits + 1 parity bit + 1 stop bit = 11 bits).

1.5.6 PREAMBLE

The preamble is always a hex 02 character (ASCII character STX = Start of Text). If enabled, this will be the first byte out in either the ASCII or BCD message format.

1.5.7 POSTAMBLE

The postamble is automatically inserted into the ASCII format. It is optional in the BCD format. The postamble comprises hex 0D, hex 10 (ASCII CR, LF) at the end of the message.

1.5.8 QUALITY INDICATOR

The quality indicator can be enabled in either ASCII or BCD format. In the BCD format a binary one in bit position one indicates an error in the input time code, while a binary one in bit position one indicates a loss of the input time code signal. In the ASCII format two bytes are used for the quality indicator (Quality 1 and Quality 2). Quality 1 byte is set to ASCII "L" (hex 4C) indicating a loss of time code input signal. Quality 2 byte is set to ASCII "E" (hex 46) indicating an error in the input time code. An ASCII "space" (hex 20) is set in both Quality 1 and 2 if there are no errors.

1.6 INSTALLATION PROCEDURE

- Disconnect the power cable from the back of the TM7000.
- Select an open option slot and remove the two assembly securing clips from the slot rails.
- Configure and verify the settings of the 21034 module before proceeding to the next step.
- Insert the module into the selected option slot, being careful that the components are on the top side of the module.

APPENDIX A

- Reattach the securing clips to the slot rails.
- Reconnect the cable to the J1 connector on the back of the TM7000.
- Apply power.

1.7 OPERATION

When power is applied to the TM7000, this module will begin to operate.

1.8 INTERFACE CHARACTERISTICS

Connector Type	25 pin "D" type.
Pin Assignments	See Figures One, Two and Three.

1.8.1 RS-232

Input Impedance	3-7K Ω .
Input Voltage Range	$\pm 25V$ maximum, 0-5V minimum.
Output Voltage	Between $\pm 5V$ to $\pm 15V$ into a load of 3-7K Ω .

1.9 MAINTENANCE

No routine maintenance is required.

1.10 SETUP CHECKLIST

Please see the next page.

1.10.1 TERMINAL SELECT AND HANDSHAKE SELECT (Box Pin Jumpers - J3)

DCE With Full Handshake
(1, A, and B through 6 A and B.)

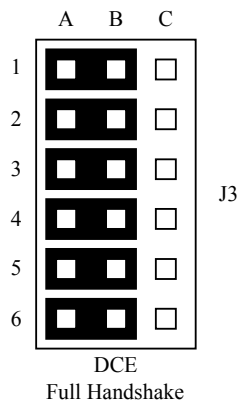

DTE with Full Handshake
 (1, B and C through 6, B and C.)

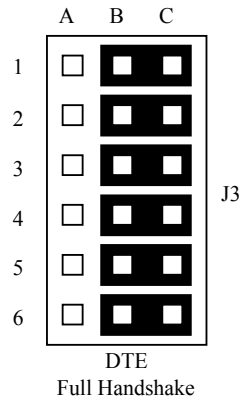

DCE with No Handshake
 (1, A and B. 2, A and B. 3 and 4 C. 5 and 6 C.)

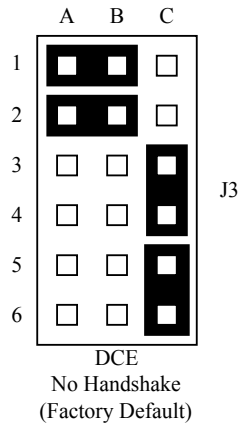

DTE with No Handshake

(1, B and C. 2, B and C. 3 and 4, A. 5 and 6, A.)

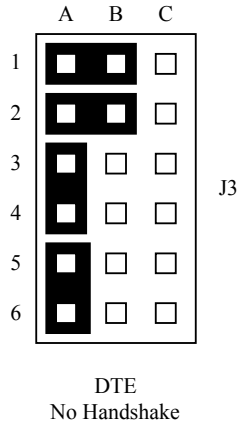

Time Select (Box Pin Jumper - J2)

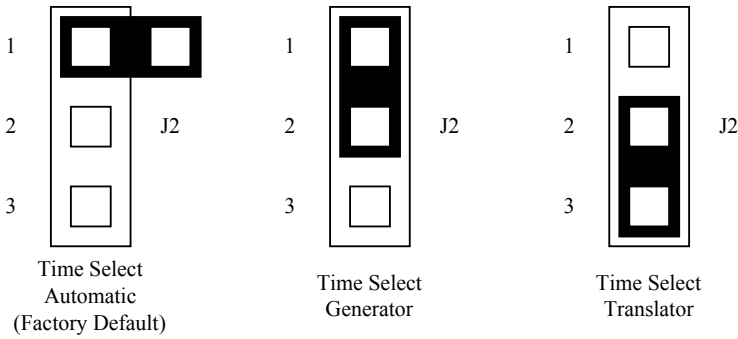

1.11 MODE OF OPERATION

Asynchronous (SW4-1 ON)

Synchronous (SW4-1 OFF)

Asynchronous Mode - Character Selection

SW3-1 through SW3-8 (1-MSB, 8-LSB)

(ON=0, OFF=1)

Mandatory Switch Setting

SW4-3 ON

1.11.1 SYNCHRONOUS MODE

Time Rate Output

- 10 PPS(SW1-1 ON, SW1-2 ON, SW1-3 ON)
- 1 PPS (SW1-1 ON, SW1-2 ON, SW1-3 OFF)
- 1P/10S(SW1-1 ON, SW1-2 OFF, SW1-3 ON)
- 1P/100S (SW1-1 ON, SW1-2 OFF, SW1-3 OFF)
- 1P/1000S (SW1-1 OFF, SW1-2 ON, SW1-3 ON)
- 1P/1000S (SW1-1 OFF, SW1-2 ON, SW1-3 OFF)
- 1P/1000S (SW1-1 OFF, SW1-2 OFF, SW1-3 ON)
- 1P/1000S (SW1-1 OFF, SW1-2 OFF, SW1-3 OFF)

1.11.2 MESSAGE FORMAT

- ASCII: SW1-5 ON
- BCD: SW1-5 OFF

1.11.3 BCD MESSAGE FORMAT

- Postamble
- None: SW1-8 OFF
- Include: SW1-8 ON

1.11.4 ASCII MESSAGE FORMAT

Word Length

- 7 Bits: SW4-2 ON
- 8 Bits: SW4-2 OFF

1.11.5 BAUD RATE

- 50 (SW2-1 ON, SW2-2 ON, SW2-3 ON, SW2-4 ON)
- 75 (SW2-1 ON, SW2-2 ON, SW2-3 ON, SW2-4 OFF)
- 110 (SW2-1 ON, SW2-2 ON, SW2-3 OFF, SW2-4 ON)
- 134.5 (SW2-1 ON, SW2-2 ON, SW2-3 OFF, SW2-4 OFF)
- 150 (SW2-1 ON, SW2-2 OFF, SW2-3 ON, SW2-4 ON)
- 200 (SW2-1 ON, SW2-2 OFF, SW2-3 ON, SW2-4 OFF)
- 300 (SW2-1 ON, SW2-2 OFF, SW2-3 OFF, SW2-4 ON)
- 600 (SW2-1 ON, SW2-2 OFF, SW2-3 OFF, SW2-4 OFF)
- 1200 (SW2-1 OFF, SW2-2 ON, SW2-3 ON, SW2-4 ON)
- 1800 (SW2-1 OFF, SW2-2 ON, SW2-3 ON, SW2-4 OFF)
- 2400 (SW2-1 OFF, SW2-2 ON, SW2-3 OFF, SW2-4 ON)
- 4800 (SW2-1 OFF, SW2-2 ON, SW2-3 OFF, SW2-4 OFF)
- 9600 (SW2-1 OFF, SW2-2 OFF, SW2-3 ON, SW2-4 ON)
- 19200 (SW2-1 OFF, SW2-2 OFF, SW2-3 ON, SW2-4 OFF)
- 38400 (SW2-1 OFF, SW2-2 OFF, SW2-3 OFF, SW2-4 ON)
- 38400 (SW2-1 OFF, SW2-2 OFF, SW2-3 OFF, SW2-4 OFF)

APPENDIX A

1.11.6 STOP BIT

- 1 (SW2-5 ON, SW2-6 ON)
- 1 (SW2-5 ON, SW2-6 OFF)
- 1.5 (SW2-5 OFF, SW2-6 ON)
- 2 (SW2-5 OFF, SW2-6 OFF)

1.11.7 PARITY

- None (SW2-7 ON, SW2-8 ON)
- Odd (SW2-7 ON, SW2-8 OFF)
- Even (SW2-7 OFF, SW2-8 ON)
- None (SW2-7 OFF, SW2-8 OFF)

1.11.8 PREAMBLE

- Preamble (SW1-6 ON)
- None (SW1-6 OFF)

1.11.9 QUALITY INDICATOR

- Quality On (SW1-7 ON)
- None (SW1-7 OFF)

Table One
ASCII Format Time Word Output
All Options On

	7	6	5	4	3	2	1	0	
Word #1 Preamble	0	0	0	0	0	0	1	0	Optional
Word #2	0	0	1	1	HD				
Word #3	0	0	1	1	8	4	2	1	
Word #4	0	0	1	1	UD				
Word #5	0	0	1	1	8	4	2	1	
Word #6	0	0	1	1	0	0	TH		
Word #7	0	0	1	1	8	4	2	1	
Word #8	0	0	1	1	0	TM			
Word #9	0	0	1	1	8	4	2	1	
Word #10	0	0	1	1	UM				
Word #11	0	0	1	1	8	4	2	1	
Word #12	0	0	1	1	TS				
Word #13	0	0	1	1	8	4	2	1	
Word #14 Quality 1	0	1	0	0	1	1	0	0	Optional Loss
Word #15 Quality 2	0	1	0	0	0	1	0	1	Optional Error
Word #16 CR	0	0	0	0	1	1	0	1	
Word #17 LF	0	0	0	0	1	0	1	0	

Table One-A
ASCII Format Time Word Output
No Options

	7	6	5	4	3	2	1	0
Word #1	0	0	1	1	HD			
					8	4	2	1
Word #2	0	0	1	1	TD			
					8	4	2	1
Word #3	0	0	1	1	UD			
					8	4	2	1
Word #4	0	0	1	1	0	0	TH	
							2	1
Word #5	0	0	1	1	UH			
					8	4	2	1
Word #6	0	0	1	1	0	TM		
						4	2	1
Word #7	0	0	1	1	UM			
					8	4	2	1
Word #8	0	0	1	1	0	TS		
						4	2	1
Word #9	0	0	1	1	US			
					8	4	2	1
Word #10	0	0	1	1	tS			
					8	4	2	1
Word #11	0	0	1	1	hS			
					8	4	2	1
Word #12	0	0	1	1	mS			
					8	4	2	1
Word #13 30H	0	0	1	1	0	0	0	0
Word #14 CR	0	0	0	0	1	1	0	1
Word #15 LF	0	0	1	1	1	0	1	0

Table Two
BCD Format Time Word Output
All Options On

	7	6	5	4	3	2	1	0	
Word #1 Preamble	0	0	0	0	0	0	1	0	Optional
Word #2	0 0 0 0				HD				
					8	4	2	1	
Word #3	TD				UD				
	8	4	2	1	8	4	2	1	
Word #4	0 0				TH		UH		
					2	1	8	4	
Word #5	0				TM		UM		
					4	2	1	8	
Word #6	0				TS		US		
					4	2	1	8	
Word #7	tS				hS				
	8	4	2	1	8	4	2	1	
Word #8	mS				0 0 0 0				
	8	4	2	1					
Word #9 Quality	0	0	0	0	0	0	L	E	Optional
Word #10 Postamble	1	1	0	1	1	0	1	0	Optional

Table Two-A
BCD Format Time Word Output
No Options

	7	6	5	4	3	2	1	0	
Word #1	0 0 0 0				HD				
					8	4	2	1	
Word #2	TD				UH				
	8	4	2	1	8	4	2	1	
Word #3	0 0				TH		UH		
					2	1	8	4	
Word #4	0				TM		UM		
					4	2	1	8	
Word #5	0				TS		US		
					4	2	1	8	
Word #6	tS				hS				
	8	4	2	1	8	4	2	1	
Word #7	mS				0 0 0 0				
	8	4	2	1					

Figure One
DCE Connections

Pin	Signal
1	GROUND
2	TXD
3	RXD
4	RTS
5	CTS
6	DSR
7	GROUND
8	Not Used
9	MATCH
10	Not Used
11	+5VB
12	Not Used
13	Not Used
14	Not Used
15	Not Used
16	Not Used
17	Not Used
18	Not Used
19	Not Used
20	DTR
21	Not Used
22	Not Used
23	Not Used
24	Not Used
25	Not Used

Figure Two
DTE Connections

Pin	Signal
1	GROUND
2	RXD
3	TXD
4	CTS
5	RTS
6	DTR
7	GROUND
8	Not Used
9	MATCH
10	Not Used
11	+5VB
12	Not Used
13	Not Used
14	Not Used
15	Not Used
16	Not Used
17	Not Used
18	Not Used
19	Not Used
20	DSR
21	Not Used
22	Not Used
23	Not Used
24	Not Used
25	Not Used

1.0 INTRODUCTION

This assembly is used to serially encode the time value contained within the TymMachine 7000. The time code format is determined by the location of various jumpers and selection of components during manufacture. The unique configuration is defined by a dash number in accordance with the following table.

<u>Assembly</u>	<u>Code Generated</u>
19393-1	IRIG A
19393-2	IRIG B
19393-3	IRIG E (100 Hz)
19393-4	IRIG E (1 kHz)
19393-5	IRIG H (100 Hz)
19393-6	IRIG H (1 kHz)
19393-7	IRIG G
19393-8	XR3 (250 Hz)
19393-9	2137 (1 kHz)
19393-10	NASA 36
19393-11	1892
19393-12	NASA 28
19393-13	IRIG C (100 Hz)

1.1 INSTALLATION

This assembly may be plugged into any available option position. Remove power from the TM7000. Plug this assembly into the PTS, being careful that components are on the top side. Interconnect the modulated output (J1) and DC LEVEL SHIFT output (J2) as desired. Apply power.

1.2 OPERATION

There are no operator controls for this option.

1.3 SPECIFICATIONS

J1 Modulated Output

Level:	Adjustable 0-5 V p-p
Impedance:	Capable of driving a 50 ohm load
Modulation Ratio:	Adjustable, nominally 3:1

J2 DC Level Shift Output (74HC type)

Level: TTL/CMOS compatible
 Load: 6 mA sink

1.4 ADJUSTMENTS

Phase: While observing the modulated output (J1) on an oscilloscope, adjust R14 for minimal discontinuity at the modulation points.

Ratio: While observing the modulated output (J1) on an oscilloscope, adjust R15 for the desired ratio. The standard modulation ratio for IRIG time codes is 3:1.

Levels: While observing the modulated output (J1) on an oscilloscope, adjust R16 for the desired level. The standard amplitude for most applications is 3 V p-p (modulated carrier), which is approximately 1 V RMS.

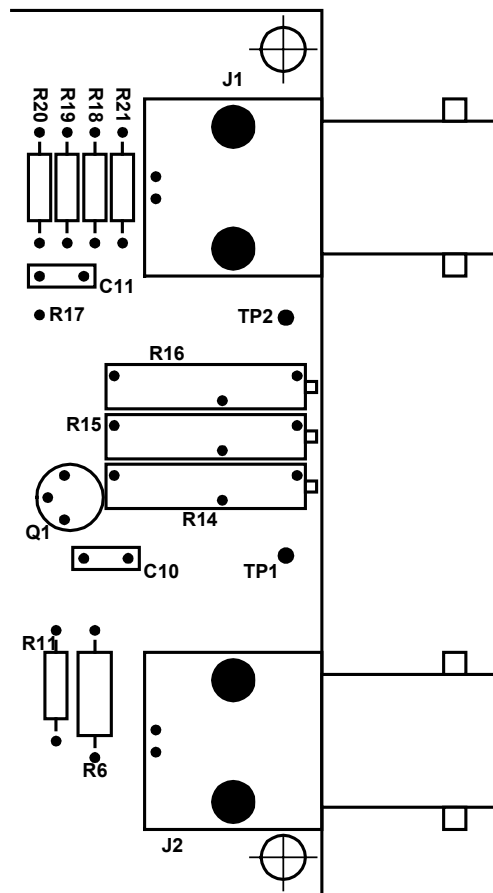

1.0 INTRODUCTION

This assembly is used to serially encode the time value contained within the TymMachine 7000. The time code format is determined by front panel menu selection.

This assembly generates IRIG A, IRIG B, IRIG G, NASA 36, XR3, 2137 or AN/GSQ-53 (250 Hz) as selected by the Output Code Menu. The time encoded may come from either the generator or the translator. Codes may be “re/generated” from the translator at multiple speeds.

1.1 INSTALLATION

This assembly may be plugged into any available option position. Remove power from the TM7000. Plug this assembly into the PTS, being careful that components are on the top side. Interconnect modulated output (J1) and DC Level Shift (J2) as desired. Select the desired channel number in the range of 1 through C hex (1-12) using the ‘piano’ switches on the rear edge of this module located between the two BNC output connectors (See switch S1 in Figure 1). Think of the channel number as an address. For ease of operation, any number of assemblies may share a common channel (address) number. Viewed from the rear of the chassis, the Channel Select switches are designated 1-2-4-8 from left to right. The UP position is the ‘on’ position (binary one). Do not use a value of zero (all switches down) nor a value that is greater than C hex (12).

1.2 OPERATION

The RE/GENERATE menu (on the SELECT GENERATOR OUTPUTS menu) is used to select the output code for each channel regardless of whether the time source for the code is the generator or the translator. Channels are selected using the NEXT button under the LCD menu display. Only installed channel numbers are displayed. Multiple encoders may be assigned the same channel number during installation, or each encoder may be assigned a different channel number. Channels are numbered in “hex” from 1 to C. All other numbers are illegal. Set-ups are stored and remembered through power outages.

The SPEED UP menu relates to the generator only. When sped up, most generator functions are inhibited (including the parallel outputs, video time insertion and J6 serial code output). START, STOP and time PRESET are preserved.

If the unit is switched to Translate while the Generator is sped up, the Generator speed is automatically switched to 1:1 (real time). The allowable generator speed up is dependent on the time code being generated. IRIG G will function up to a 4:1 increase, while all other codes will work properly from 1:1 up to 32:1. The 32:1 speed is about one percent fast. The generator speed must be manually returned to 1:1 in order for the re/generate function to work correctly. Merely switching to the Translate mode will not assure proper regenerate operation.

NOTE

Following a change in selected code output or speed up (greater than 1:1 only) up to 100 seconds of code time may be required before the outputs are stable. Switching to a 1:1 (real time) speed will produce correct outputs immediately.

The term ‘re/generation’ refers to generating a time code output with the same time information as an input time code to the Translator. Output code selection is performed as described above. Input code selection is performed using the normal Translator controls. For re/generation to function correctly, the PTS must know the speed of the input and the output. This is accomplished using the FILTER menus to select ENVELOPE FILTER IN and PLAY SPEED RATIO to select the rate of the input and output. When the input code is changed, these selections must be made again.

Any available output may be re/generated from any translated code with a (real time) frame period of one second or less. The allowable speed range is 1:1 through 64:1 for all input codes except IRIG G, which has a maximum rate of 2:1, and IRIG A, which has a maximum rate of 16:1.

The Multi-Code Serial Encoder may set time information from either the Generator or Translator according to which mode has been selected. Or, it may be forced by a jumper to output either translator time or generator time, regardless of the mode of the PTS. Placing a jumper from E2 to E3 forces Translator time output. Placing a jumper from E2 to E1 forces the output of Generator time. This assembly is shipped with a jumper installed from E2 to E1 to force Generator time. Power must be cycled for a jumper change to be effective.

Note: Power must be cycled for a jumper change to be effective.

1.3 SPECIFICATIONS**J1 DC Level Shift Code Output (74HC type)**

Level: TTL/CMOS compatible
Load: 4 mA sink

J2 Modulated Code Output

Amplitude: Adjustable 0-5 V P-P
Impedance: Capable of driving a 50 ohm load.
Modulation Ratio: Adjustable, nominal 3:1

Note: Re/generated time codes are within one millisecond of the input time code.

1.4 ADJUSTMENTS

Ratio: While observing the modulated output (J2) on an oscilloscope, adjust R17 for the desired ratio. This is normally 3:1 (mark:space amplitude) for an IRIG time code.

Level: While observing the modulated output (J2) on an oscilloscope, adjust R15 for the desired amplitude. The normal factory setting is 3 V P-P (mark amplitude).

Select Generator Outputs
ID on-OFF LS on-OFF SPEEDUP RE/GEN

RE/GEN

Select Desired Channel N Output Code
IRIG A--B--G NASA 36 XR3 2137 ANG

Notes:

1. "N" is the current Encoder channel. Advance with the NEXT button.
2. Select the desired output code with a button directly under the menu item.
3. Only installed channels are displayed.

SPEED UP

Select Desired Generator Speed up
X1 X2 X4 X8 X16 X32 X64

Figure 1

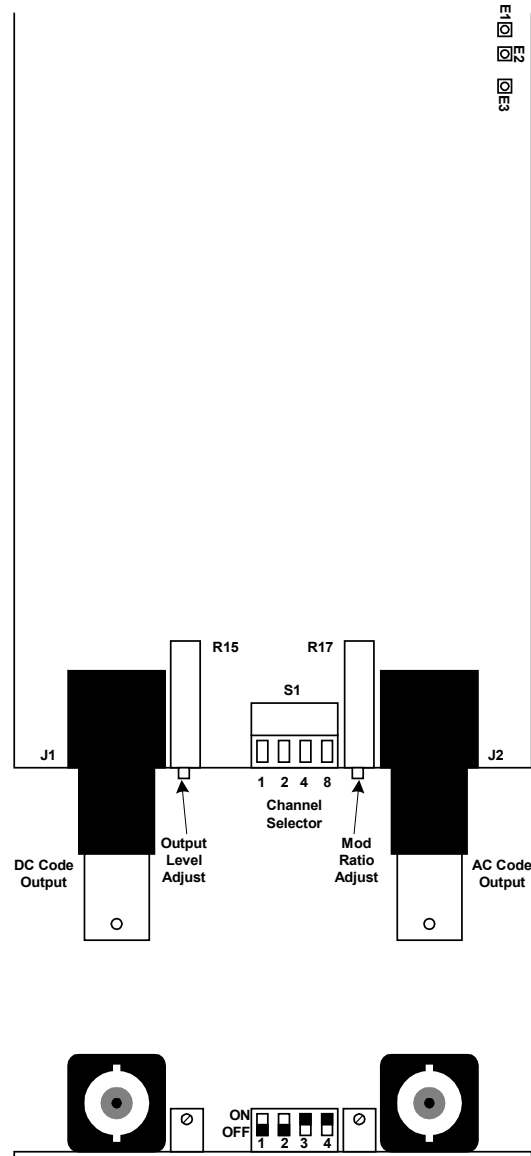

Shown with Channel C (12) Selected

TM Option 17**Read DC Code****Assembly 19395****1.1 INTRODUCTION**

This assembly is used to provide multi-speed DC code translating abilities in the TymMachine 7000. DC codes are input to this module, which provides a code output that must be externally connected to the Translator Code input J8.

1.2 INSTALLATION

This assembly may be plugged into any available option position but should preferably be located near J8.

- Remove power from the TM7000.
- Plug this assembly into any unused option slot, being careful that components are facing upward.
- Connect the DC code in to J3 of this assembly to the Code Input (J8) of the basic unit using the coaxial cable supplied.
- Apply power.

1.3 SPECIFICATIONS

DC Code

Input Impedance: $\geq 8K$ Ohms
 Input Level: +1V to +50V_{peak}, positive, negative or bi-polar.
 Polarity: NORM/INV is selected by the Translating Menu.
 Tracking Range: Selected Frequency $\pm 20\%$.

Speed Range:

<u>Code Selected:</u>	<u>Range (playback: real-time)</u>
IRIG G	1:1-4:1
IRIG A	1:1-32:1
IRIG B, E, H	1:1-256:1

1.4 OPERATION

The Select VERSATILE DISPLAY function Menu is shown in Figure 1. Selecting TRANSLATOR from this menu by pressing any switch under TRANSLATOR will result in the Warning Message, Figure 2, being displayed on the LCD.

Select VERSATILE DISPLAY function Menu



Figure 1

Warning Message

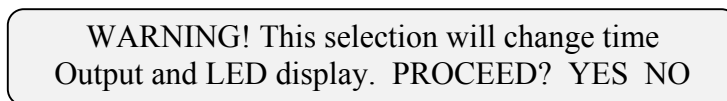

Figure 2

Selecting “YES” will result in the Set-Up Translator Menu Figure 3 being displayed on the LCD. If “NO” is selected the previous menu and mode remains intact.

Set-Up Translator Menu



Figure 3

Select DC code by depressing the switch directly below DC. The selected code will be in upper case letters. When DC is in upper case letters, AC code translation is inhibited. When DC is in uppercase letters translation of DC code is enabled.

Pressing the PREV switch will return the LCD Display to that of the Select VERSATILE DISPLAY function Menu shown in Figure 1.

Pressing the NEXT switch will cause the LCD Display to change to the Select Desired Code Family Menu as shown in Figure 4.

Select Desired Code Family Menu



Figure 4

APPENDIX A

This menu and the following menu descriptions are used to allow the user to select type of Serial Time Code being input to the Translator.

Selecting IRIG, by pressing the switch below IRIG, leads to the Select Desired IRIG Code Menu as shown in Figure 5, on the LCD Display, allowing the user to select any of the IRIG Serial Time Codes shown to be translated. Selecting NASA changes the LCD Display to the Select Desired NASA Code Menu, Figure 6 and selecting XR3/2137 causes the Select Desired XR3/2137 Code Menu, Figure 7 to be displayed on the LCD Display screen.

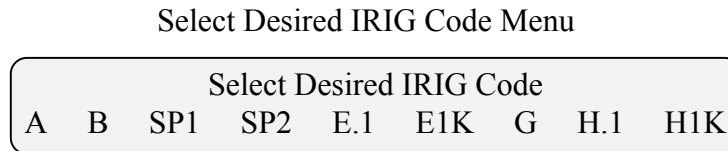

Figure 5

The Select Desired IRIG Code Menu allows the user to select the desired IRIG Serial Time Code to be translated by the Translator.

Pressing the PREV switch while this menu is shown on the LCD Display will return it to the Set-Up Translator Menu, Figure 3.

A blinking cursor appears at the presently selected IRIG code to be translated. If the desired code has been selected, pressing the NEXT switch will cause the Translating Menu, Figure 8 to be displayed on the LCD Display.

If there is not a blinking cursor on this menu no IRIG code has been selected. If it is desired to see what input code has been selected press the NEXT switch and the Translating Menu, Figure 8, will appear on the LCD Display showing the selected Translator code selected in the upper right hand corner after “Translating”.

If the input code is different from that shown on the display, it is necessary to select the correct code. Changing the code selection is accomplished by pressing the switch beneath the desired code. When the new desired code is selected, the LCD Display will change to that shown in Figure 8 with the selected code being translated shown in the upper right hand corner of the display.

The selection of SP1 or SP2 are reserved for translation of special codes, and the message “Selected option is not installed...(See Figure 11) will appear. If either one of these special codes are provided, its option description will be inserted at the end of this Appendix.



Figure 6

The Select Desired NASA Code Menu, Figure 6, is used to select the NASA code to be translated. If the code has previously been selected, skip to the Translating Menu, Figure 8, by pressing NEXT. To select a code, push the corresponding switch.

Pressing the PREV switch while the Translating Menu is shown on the LCD Display will return it to the Set-Up Translator Menu, Figure 3.

A blinking cursor will appear on the selected code to be translated. If the desired code has been selected, pressing the NEXT switch will cause the Translating Menu, Figure 8, to be displayed on the LCD Display.

If no blinking cursor appears on this menu, none of the NASA codes has been selected. Pressing the NEXT switch causes the Translating Menu Figure 8 to appear on the LCD Display showing the selected Translator Code in the upper right hand corner after “Translating”.

Should the input code be different from that previously selected, it is necessary to select the correct code. Selecting the correct code is accomplished by pressing the switch beneath the desired code. When the new code selection is made, the LCD Display will change to that shown in Figure 8 with the selected code being translated shown in the upper right hand corner of the display.

Selection of 28.1 corresponds to NASA 28 with a carrier frequency of 100 Hz. Selection of 28K corresponds to NASA 28 with a carrier frequency of 1KHz. (Optional)

Select Desired XR3/2137 Code Menu



Figure 7

The Select Desired XR3/2137 Code Menu, Figure 7, is used to select a member of the XR3 time code family to be translated. If the desired code has previously been selected, skip to the Translating Menu, Figure 8 by pressing NEXT.

To select a code from this group, push the corresponding switch below the displayed code. Upon selection of a new code, the LCD Display will change to that shown in Figure 8 with the selected code being translated shown in the upper right hand corner of the display.

Translating Menu

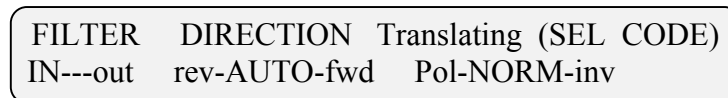

Figure 8

APPENDIX A

This menu is normally displayed while translating. It shows the code being translated and the Filter, Direction, and Polarity selected.

When any switch under FILTER “IN --- OUT” is selected from the Translating Menu, the LCD Display changes to the Select Filters Menu screen Figure 9.

When a switch is pressed below rev, auto or fwd under “DIRECTION” the direction is selected. The selected DIRECTION will be displayed in upper case letters. When REV is selected, the Translator is forced into Reverse. When AUTO is selected, Auto Forward/Reverse detection is enabled. When FWD is selected, the Translator is forced into Forward.

Pressing the switch below norm or inv after Pol selects the Polarity of the incoming code. The selected Polarity will be displayed in upper case letters. NORM selects Normal Polarity and INV selects Inverted Polarity.

If the code into the TM7000 has normal Polarity, “NORM” should be selected. If the input code is inverted, “INV” should be selected. When the direction of the input code is reversed, a Polarity inversion takes place automatically to provide optimal translating capability.

The update rate of translated time on the LED Display is changed according to the code being translated, and the rate (real time versus speed-up). This can cause a peculiar appearance of the time display. If, for example, the seconds update ten times as fast as the display, they would not appear to change. Changing the code speed slightly could cause the seconds display to increment (or even decrement) at a slow rate. This phenomenon only occurs at rates much faster than real time.

Pressing NEXT or PREV will change the LCD Display to the Warning Message screen, Figure 3, which forces the user to make a decision on whether to proceed or not to proceed. Making the decision to Proceed “YES” returns the LCD Display to the Select Versatile Display Function Menu, Figure 1 allowing the user to select the PTS operating mode in which to operate.

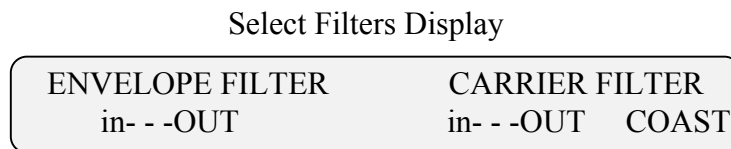

Figure 9

The Select Filters LCD Display as shown in Figure 9, provides for the enabling and disabling of independent filters for the Envelope and Carrier of the input code.

The Carrier Filter is a band pass filter, implemented with a Phase Lock Tracking filter, designed to remove extra, and/or supply missing carrier cycles.

The “COAST” switch enables/disables freewheeling during dropouts or loss (below the threshold set by R46, on the Translator Assy.) of input code. If the Read DC Code option is enabled, disable the carrier filter.

The Carrier Filter must be IN (enabled) for the “COAST” function to operate.

When “COAST” is displayed in upper case letters, it is enabled. If “coast” is in lower case letters, it is disabled.

Note: When reading codes with more than one second between elements, adjust the threshold for “space” cycles or enable “COAST” to prevent discontinuous translation.

The Envelope Filter is a two pole low pass filter designed to improve performance by removing higher frequencies from the input code.

When “IN” under ENVELOPE FILTER is selected, it will be in upper case letters and “out” will be in lower case letters. When IN, Filters appropriate to the real-time rate of the code are enabled. The appropriate filter for the code selected is preset when the input code is selected. For uncontrolled speed-up operation, the Filter should be selected OUT, or higher than the fastest speed expected.

When NEXT is pressed while the Select Filters Display is shown on the LCD Display it will change to the Play/Search Speed Menu as shown in Figure 10. Note that either (or both) the Envelope Filter or the Carrier Filter have to be selected IN to get this menu.

For this option to operate correctly, the ratio of playback speed to real time must be entered (PB:RT) using the Play/Search Speed Menu. This menu has provisions for PLAY SPEED RATIO and SEARCH SPEED RATIO.

The latter is disabled in units without the Tape Search Option.

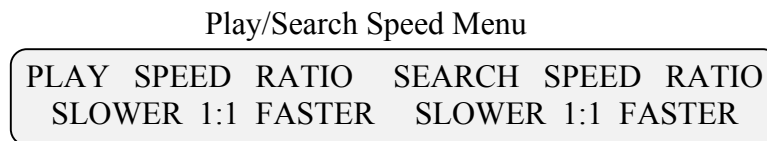
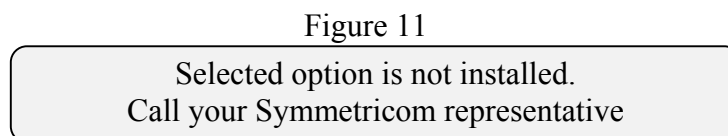

Figure 10

Speed Ratios are changed by use of the FASTER or SLOWER switches. 1:1 is automatically selected when the selected code is changed. DC code will operate in reverse only when using the Tape Search Option. DC Code requires several seconds to acquire lock and start translating.

Selection Not Installed Display



APPENDIX A

For DC Code operation, the envelope filter should be selected “IN”, and the carrier filter should be selected “OUT”.

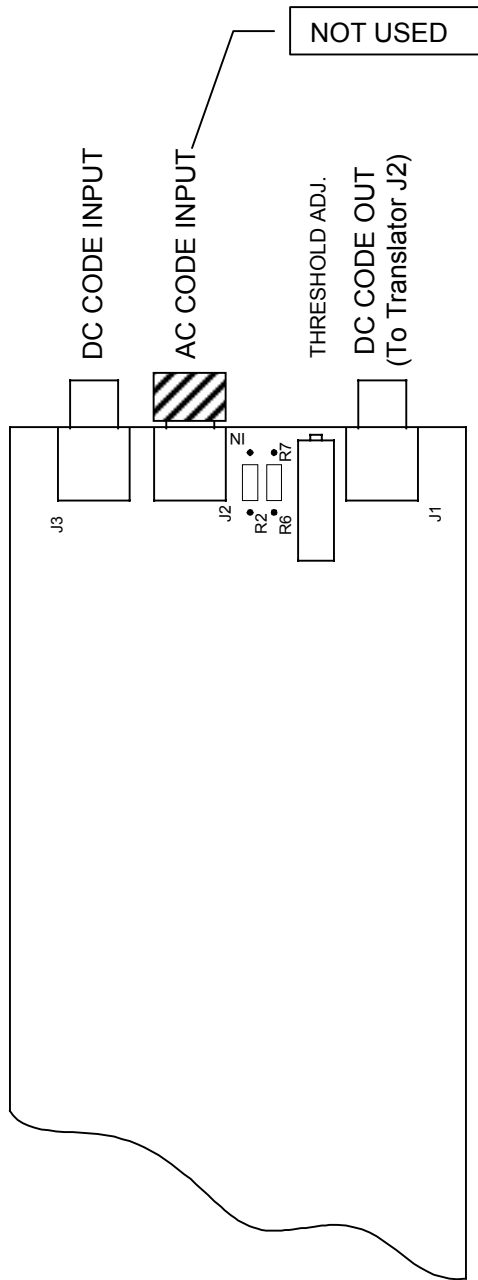

Figure 12
INPUT/OUTPUT AND ADJUSTMENT LOCATION

TM Option 18**Slow Code****Assembly 19400****1.0 INTRODUCTION**

This assembly is used to provide the serial Five-Rate Slow Code time output for the user.

1.1 SLOW CODE DESCRIPTION

The serial code (see Figure 1) is a 33-bit, amplitude and pulse-width modulated DC level-shift code. The code is composed of a reference marker, four code words, or seconds, minutes, hours, and days, followed by index markers to complete the time frame. Each code word contains sub-words as necessary to represent the units, tens, and hundreds of units. Each sub-code is weighted in a binary coded decimal (BCD) manner.

Codes 1, 2, and 3 have a frame length of 50 precise intervals. Codes 4 and 5 have a frame length of 60 precise intervals. Leading edges of all pulses are coincident with the leading edges of the time code frame intervals.

One pulse is deleted at the beginning and the end of each code word between each sub-code word. Index markers complete the time frame after the time-of-year word has been read.

The amplitude and pulse-widths of the time frame information are as follows:

AMPLITUDE

Binary 1	+5V DC nominal
Binary 2	+2V DC nominal

PULSE WIDTH

Reference Marker	100% of bit interval
Binary 1	50% of bit interval
Binary 0	20% of bit interval

1.2 INSTALLATION

This assembly may be plugged into any available option position. Remove power from the TM7000. Plug this assembly into the PTS, being careful that components are on the top side. Interconnect to the desired destination equipment. Apply power.

1.3 OPERATION

Operation of this option is normally transparent to the user. Selection of the output automatically follows the operating mode so that the time displayed on the TM7000 LED display, whether translator or generator, is output in the serial word. The user may optionally defeat this automatic selection by the installation of a jumper. To force continuous output of generated time, jumper E1 to E2. To force continuous output of translated time, jumper E2 to E3.

TRANSLATOR SETUP



SLOW CODE

CODE FRAME PERIOD (REAL TIME)

Selection is provided by the Select Slow Code Rate menu shown below. This option only operates at 1:1 (real time) and slower.

SELECT SLOW CODE RATE

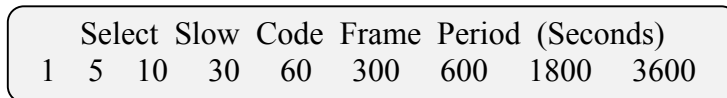

1.4 SPECIFICATIONS

SLOW CODE OUTPUT

Format	Symmetricom Slow Code.
Level	Adjustable 0-5V peak.
Impedance	Capable of driving a C-MOS load, a TTL load or a 1K Resistive load.
Modulation Ratio	Nominally 5:2.

ADJUSTMENTS

Level	While observing the modulated output (J1) on an oscilloscope, adjust R4 for the desired level.
-------	--

**Figure 1
Slow Code Output/Level Adjustment**

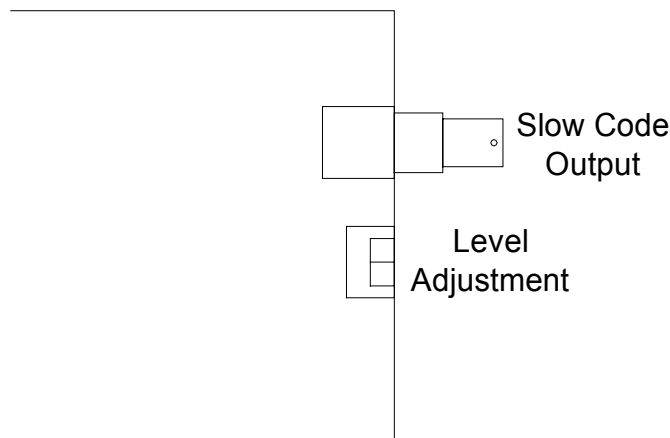

Bi-Level — 5-Rate Slow Code

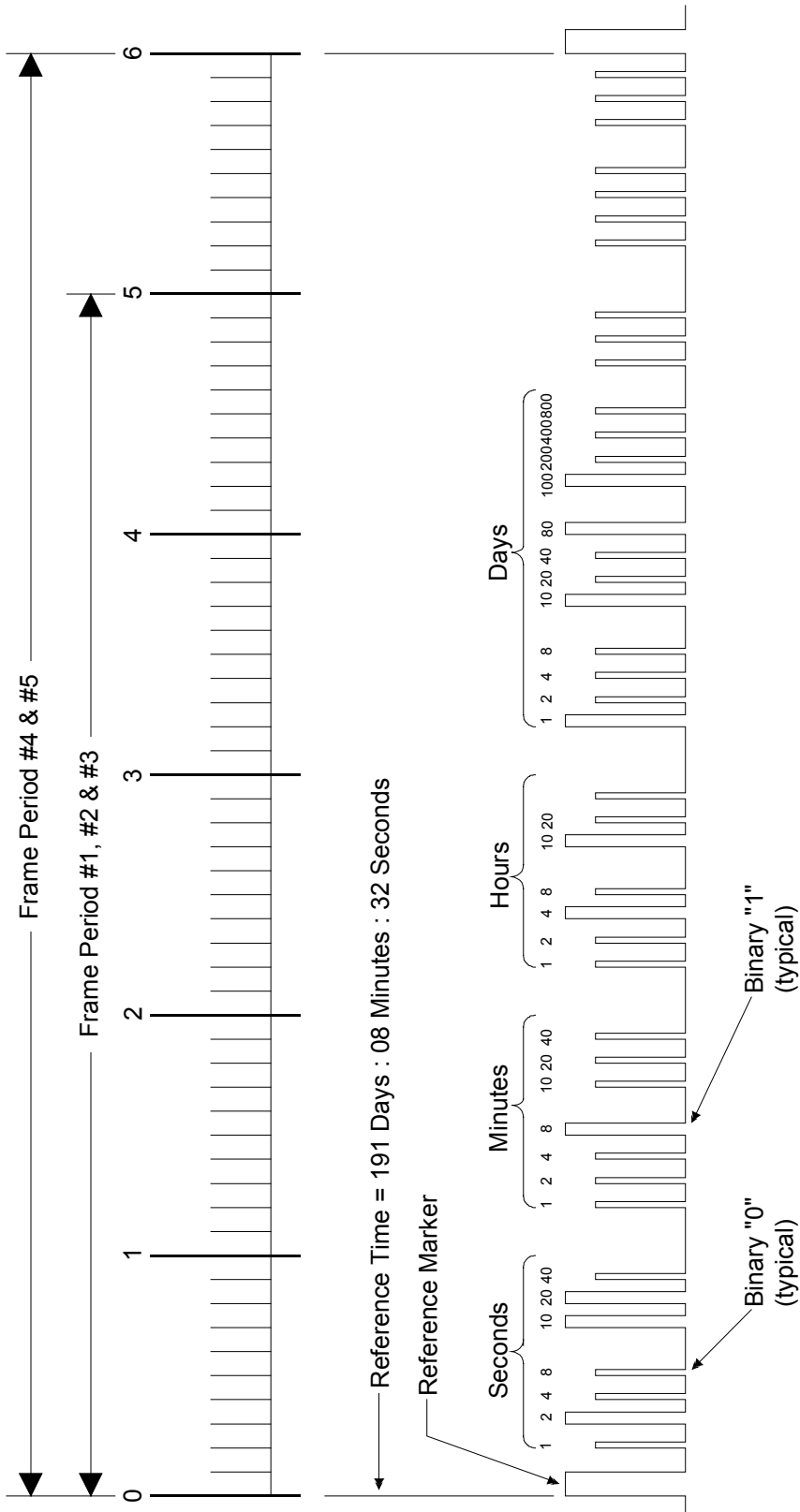

C	O	D	E	Pulse Rate	Frame Period	Binary Zero	Binary One	Frame Ref. Pulse
1	50 PPS	1 Sec	4 mS	10 mS	20 mS			
2	10 PPS	5 Sec	20 mS	50 mS	100 mS			
3	5 PPS	10 Sec	40 mS	100 mS	200 mS			
4	1 PPS	60 Sec	200 mS	500 mS	1 Sec			
5	1 P/10s	10 Min	2 Sec	5 Sec	10 Sec			

1.0 INTRODUCTION

Assembly 20125 is functionally identical to Assembly 100006 except that it uses different integrated circuits. All the Specifications, Controls, and Adjustments are the same.

Note: Two configurations of this module are available.

TM Opt 27A: Uses Assembly 20125-1 or 100006-1. Processes composite video. Input and output connectors are BNC type.

TM Opt 27B: Uses Assembly 20125-2 or 100006-2. Processes y-c (S-Video) signals. Input and output connectors are industry standard 4-pin DIN connector. DIN-to-BNC adapter cables are furnished with this configuration to allow composite video to be processed.

This assembly accepts as its inputs a video signal from a video camera or other similar source and time of year information from the TymMachine 7000 data bus. After synchronizing to the video input signal, the time of year information is reformatted for insertion into the video signal.

The video input signal and the time data are routed to a modulator/output amplifier where they are combined to provide a composite video suitable for connection to a video recorder or to a video monitor. When the output signal is connected to a video monitor, the TM7000 time information will appear in a human-readable format, superimposed over a portion of the video signal.

On-board controls allow vernier positioning of the inserted characters in both the vertical and horizontal axes, control of aspect ratio (character height and width) insertion or deletion of a shaded mask around the inserted characters, progressive deletion (one digit at a time) of sub-seconds information, deletion of days information, or disabling of the inserter altogether.

Additional controls are provided for vernier shading adjustment of the inserted characters and of the shaded mask from black through white.

1.1 INSTALLATION

This assembly may be installed in any available TM7000 option location. Remove power from the TM7000. Refer to page A-47 and set up switches S1-1, 2 and 3 as dictated by system performance requirements. Insert the assembly into the TM7000, insuring that the components are oriented toward the top of the TM7000. Connect the video input signal to J3 and the video output signal via J2. Reapply power. The Video Time Inserter assembly is now operable.

The Second Line Video Assembly is designed for installation in the option location immediately to the right of (as viewed from the rear of the TM7000) and in the same horizontal plane as this assembly. This places a restriction on installation of the Video Inserter when being installed in conjunction with a Second Line Video Assembly.

1.2 OPERATION

The Video Time Inserter is specified for operation when the TM7000 is operating in the generator mode or when translating any of the available time code formats at real time (1:1) in the forward direction. The resolution is equal to the carrier frequency of the time code being translated or 1mS, whichever is less. The circuit will also operate when translating any of these time codes at accelerated rates in either forward or reverse direction, but with reduced performance.

The inserted time value is current to the start of each video frame, with the same time value being inserted in both fields of each frame. Time storage occurs during Line 3 of Field 1. Inserted time ambiguity is plus or minus one millisecond in the generator mode. In the translator mode, time ambiguity is a function of the carrier frequency of the code being translated as well as the rate and direction of translation.

Provisions have been made to allow the time value to be current to the start of each video field. Refer to the "Time Storage Rate Selection." Certain limitations to this feature apply when operating with some video formats. Refer to the following paragraph and "CAUTION" note.

The inserter will accept a variety of 2:1 interlaced video formats having a number of vertical interval timing wave forms (refer to the "Specifications" paragraph). When operating with NTSC/EIA Specification RS170, CCIR/PAL, EIA Specification RS330 ("broadcast" format) or EIA Specifications RS343 (875-line, "broadcast" format) time data storage may be made at either the field rate or frame rate, as described above.

*** * * CAUTION * * ***

When operating with interlaced formats having other than "broadcast" format vertical interval wave forms, or when operating with single-field, non-interlaced formats, it will be necessary to select field rate storage of time data. If this is not done, this inserted time data will be static (not updated).

The time value which will be inserted into the video output will be dependent upon the TM operating mode (i.e. the inserted time will follow the TM time display). Provisions have been made for insertion of generator time only or translator time only, irrespective of TM operating mode. Refer to the "Data Source Selection" paragraph.

Other than time rate storage selection, as described above, the inserter requires no adjustment for operation with any of the 525-line or 625-line formats. For operation with the 875-line format, refer to the "875-Line Selection" paragraph.

1.3 CONTROLS AND ADJUSTMENTS

Refer to Figure One for location of the following controls and adjustments:

Note: When this assembly left the factory, it was adjusted as follows: full, 16- character display, small characters (9 lines per field) with black characters and gray mask, horizontally positioned near the bottom of the display. These conditions were adjusted while operating with the NTSC video format (or with a 525-line Y-C video signal, if specified for Y-C operations at the time of purchase). If this assembly is to be periodically configured for use with more than one video format, it may be necessary to re-adjust some of the following controls. This is especially true of the horizontal position and character width controls when configuring for use with one of the 875-line formats.

1.3.1 VERTICAL POSITION POTENTIOMETER R26

Used to position the inserted characters vertically in the video output signal. Clockwise operation moves the inserted characters lower in the display. Positioning is performed in increments of four horizontal lines. Vertical jitter will occur as the vertical delay control reaches each four-line "threshold." For jitter-free performance, it will be necessary to "feel" the thresholds on either side of the desired position and set the positioning control approximately equidistant from each threshold. Excessive clockwise operation may adversely affect circuit operation.

1.3.2 HORIZONTAL POSITION POTENTIOMETER R24

Used to position the inserted characters horizontally in the video output. Clockwise operation moves the inserted characters to the right in the display. Excessive clockwise operation may adversely affect circuit operation.

1.3.3 CHARACTER WIDTH POTENTIOMETER R29

Used to vary the width of the inserted characters. Clockwise operation increases the width of the characters in the display. Excessive clockwise operation may adversely affect circuit operation.

*** * * CAUTION * * ***

Excessive clockwise or counterclockwise operation of either of the following controls may adversely affect some of the video signal processing equipment which may be connected to the Video Output connector, such as video recorders and time base correctors. It is suggested that all equipment be interconnected and tested as a system prior to beginning a critical mission.

1.3.4 CHARACTER LEVEL POTENTIOMETER R38

Used to adjust the shading of the inserted characters in the video output. Clockwise operation increases character "whiteness."

1.3.5 MASK LEVEL POTENTIOMETER R43

Used to adjust the shading of the mask, if enabled, in the video output. Clockwise operation increases mask “whiteness.”

Note: In the following discussion of the various DIP switches, “closed” refers to the ON position, as marked on the DIP switch assembly.

1.3.6 S1-1, S1-2 SUB-SECONDS DATA CONTROL

Used to control the amount of sub-seconds data being inserted into the video output. When generator time is being inserted (refer to the DATA SOURCE SELECTION paragraph on page five) all three digits of sub-seconds (tenth-seconds, hundredth-seconds, milliseconds) are available. When inserting translator time, sub-seconds data availability is a function of the carrier frequency of the time code being translated by the TM7000. For example, when translating IRIG E100 or NASA 28, the unit milliseconds digit (if enabled) will be held to “0.” Refer to Table One below for sub-seconds data selection.

**Table One
Sub-Seconds Data**

Fractional Seconds	S1-1	S1-2
tS, hS, mS	CLOSED	CLOSED
tS, hS	OPEN	CLOSED
tS	CLOSED	OPEN
NONE	OPEN	OPEN

1.3.7 S1-3 DAYS INSERTION CONTROL

Used to control insertion of days data into the video output. When S1-3 is closed, days data is deleted from the video output. To enable days data, open S1-3.

1.3.8 S2-1 TIME DATA CONTROL

Used to control the insertion of the time to the video output. When S2-1 is closed, the time is deleted from the video output. To enable the time data, open S2-1.

1.3.9 S2-2 MASK CONTROL

Used to control the mask of the video to the video output. When S2-2 is closed, the mask is removed from the video output. To enable the mask, open S2-2.

1.3.10 S2-3, S2-4 CHARACTER SIZE

Used to control the vertical size (in horizontal lines-per-field) of the inserted characters. When the inserter is used with a 2:1 interlaced video signal such as RS-170 or RS-330, the character height per video frame will be double the indicated value. Since the character height is a specific number of horizontal lines, apparent height (percent of picture) will vary between video formats. Refer to Table Two for size selection.

**Table Two
Character Height**

Size	S2-3	S2-4
9 Lines	CLOSED	CLOSED
18 Lines	OPEN	CLOSED
36 Lines	CLOSED	OPEN
72 Lines	OPEN	OPEN

1.3.11 TIME STORAGE RATE SELECTION

As shipped from the factory, time data is stored coincident with the leading edge of the vertical sync pulse in the odd field (Field One) of each frame. The same time value is inserted in both fields of each frame. To cause a new time value to be inserted in both fields of each frame, solder an insulated bus wire jumper (not supplied) between the Storage Rate Select “E” points, E8 and E9. Refer to Figure One for “E” point location.

1.3.12 DATA SOURCE SELECTION

As shipped from the factory, the inserted time value follows the TM7000 operating mode. To insert generator time only, solder a short, insulated bus wire jumper (not supplied) between E1 and E2. To insert translator time only, solder this jumper between E2 and E3. Be careful not to connect E1 (+5 volts) to E3 (ground). Refer to Figure 1 for “E” point location.

*** * * CAUTION * * ***

Only one jumper should be installed or TM7000 operation will be impaired. To revert to the “as shipped” configuration, remove and discard the jumper.

1.3.13 875-LINE SELECTION

To use the 875-Line video format, solder an insulated bus wire jumper (not supplied) between the 875-Line Select “E” points, E4 and E5. Refer to Figure One for “E” point location. Adjust R24 (horizontal position) fully counterclockwise. Apply power to the PTC. While observing the output in a monitor, adjust R29 (character width) counterclockwise as required to obtain a usable set of displayed characters (no character “tearing”). Re-adjust R24 and R29 as required for character placement and horizontal size.

1.4 SPECIFICATIONS

J3 - VIDEO INPUT

The inserter will accept a wide variety of 2:1 interlaced video formats including, but not limited to, the following:

- NTSC/EIA Specification RS170, 525 lines per frame, 30 frames per second.
- EIA Specification RS330, 525 lines per frame, 30 frames per second.
- CCIR/PAL, 625 lines per frame, 25 frames per second.
- EIA Specification RS343 at 875 lines per frame, 30 frames per second.

The circuit will accept EIA Specifications RS330 and RS343 (875-line) formats having any one of the three vertical interval wave forms as described in the referenced specifications (“broadcast”, “industrial”, “military”). Operation with either the “industrial” or “military” wave forms (without equalization pulses in the vertical blanking interval) will require selection of field rate time storage (refer to the “Time Storage Rate Selection” paragraph above).

The inserter will also accept some single-field, non-interlaced video formats. In the absence of a published standard of these formats, operation must be considered on a case-by-case basis. Testing of this circuit has been performed using a limited number of non-interlaced formats.

The Assembly 20125-2 will accept a 525-line Y/C (separated luminance and chrominance signals).

Input Level is One volt, $\pm 10\%$, peak-to-peak, into a load of 75Ω , $\pm 10\%$, to ground.

Through-put frequency response is within ± 3 dB from 25 Hertz to 10 Megahertz.

The input is terminated with 75Ω , $\pm 10\%$, to ground. When operating with Y/C video, both the Y and C inputs are terminated with 75Ω .

J2 - VIDEO OUTPUT

FORMAT

Same as the input, containing inserted characters.

OUTPUT LEVEL

Nominally the same as the input, into a load of 75Ω , $\pm 10\%$, to ground.

**J2 and J3
Y/C Pin Assignments**

Pin Number	Assignment
1	Luminance Return
2	Chrominance Return
3	Luminance Input
4	Chrominance Input

Figure One

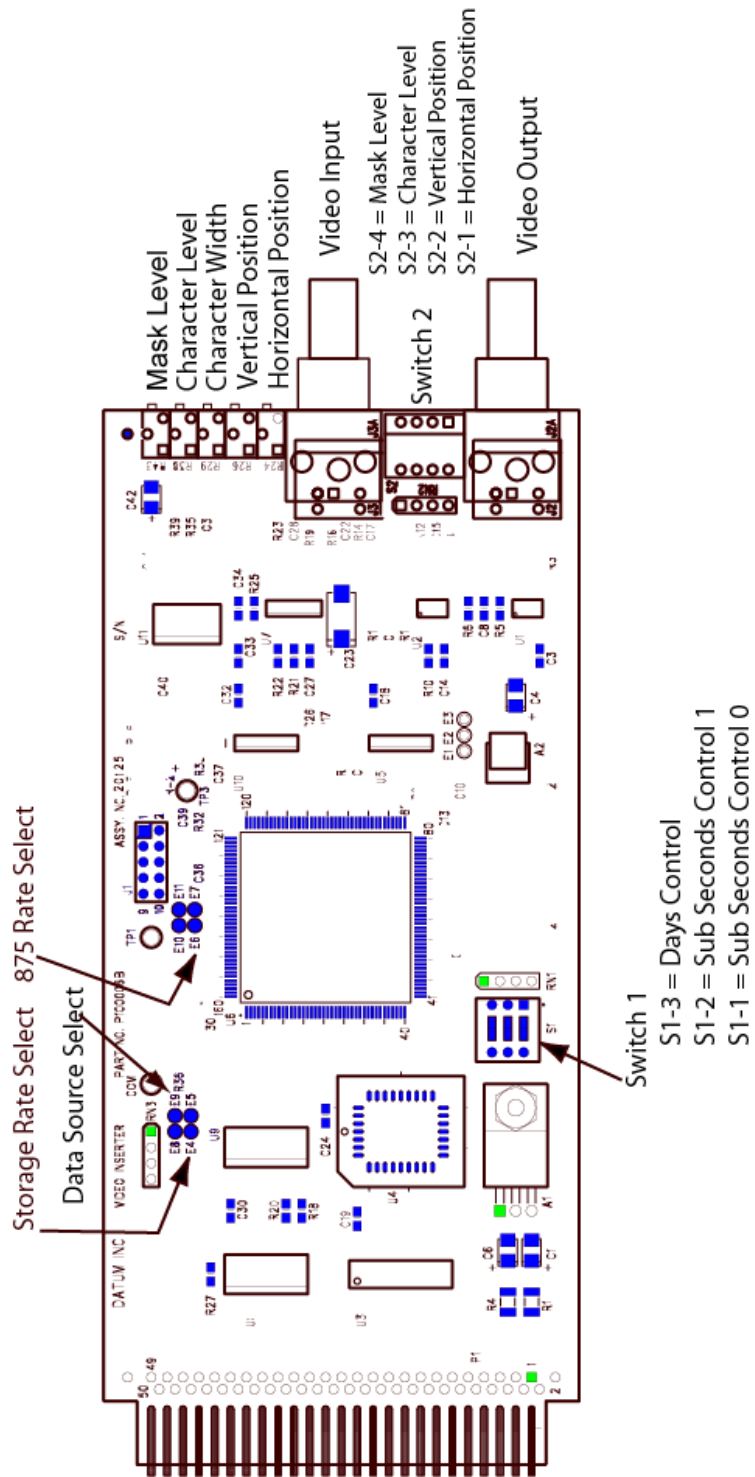

TM Option 32

Distribution Module, 600Ω Driver

Assembly 20134

1.0 INTRODUCTION

This assembly provides three buffered outputs for each input which must be provided from an external source. Each output is via a unity gain buffer.

This assembly has three inputs and nine outputs.

1.1 INSTALLATION

This assembly may be plugged into any available position.

Remove power from the TM7000. Plug this assembly into the TM7000 being careful to locate the components on the top side. Be sure inputs J1, J5, and J9 (if applicable) are connected before plugging the assembly in. Power up the unit.

1.2 OPERATION

There are no operator adjustments for this option.

1.3 SPECIFICATIONS

Table One

Input/Output	Level/Load/Frequency	Detail
Input J1	Level	Up to 1.5 VRMs.
	Load	Greater than 100KΩ.
	Frequency	DC to 1.2 MHz.
Outputs J2, J3, and J4	Level	Dependent on input.
	Load	600Ω or greater.
	Frequency	DC to 1.2 MHz.
Input J5	Level	Up to 1.5 VRMs.
	Load	Greater than 100KΩ.
	Frequency	DC to 1.2 MHz.
Outputs J6, J7, and J8	Level	Dependent on input.
	Load	600Ω or greater.
	Frequency	DC to 1.2 MHz.

Table One, Continued...

Input/Output	Level/Load/Frequency	Detail
Input J9	Level	Up to 1.5 VRMs.
	Load	Greater than 100KΩ.
	Frequency	DC to 1.2 MHz.
Outputs J10, J11, and J12	Level	Dependent on input.
	Load	600Ω or greater.
	Frequency	DC to 1.2 MHz.

1.4 INPUT/OUTPUT

Using Jumpers E1, E2, E3, and E4 allows the user to use one input and set multiple outputs.

Table Two

Input	Jumper	Outputs
J1	None.	J2, J3, J4.
J5	None.	J6, J7, J8.
J9	None.	J10, J11, J12.
J1 or J5	E1 to E2.	J2, J3, J4, J6, J7, J8.
J5 or J9	E3 to E4.	J6, J7, J8, J10, J11, J12.
J1, J5, or J9	E1 to E2, and E3 to E4.	All Outputs.

Figure One

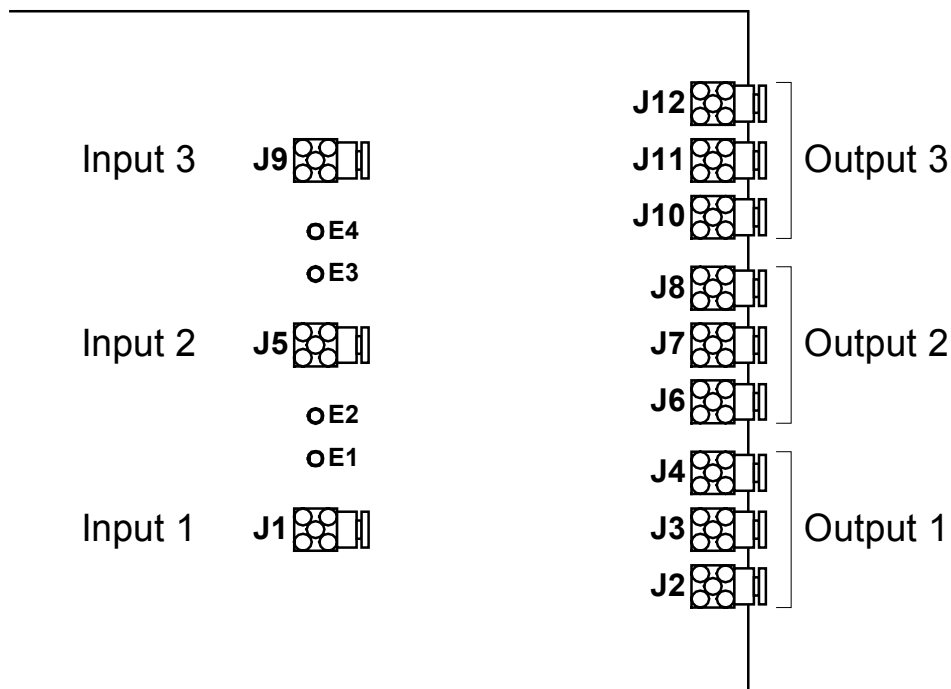

TM Option 39

Distribution Module, 50Ω Driver

Assembly 21006

1.0 INTRODUCTION

This assembly provides three buffered outputs for each input, which must be provided from an external source. Each output is via a unity gain buffer.

This assembly has three inputs and nine outputs.

1.1 INSTALLATION

This assembly requires 2 vertical slots. The assembly may be installed in any available lower slot.

Remove power from the TM7000. Plug this assembly into the TM7000 being careful to locate the components on the top side. Be sure input(s) J1, J5, and J9 (if applicable), are connected before plugging assembly in.. Power up the unit.

1.2 OPERATION

There are no operator adjustments for this option.

1.3 SPECIFICATIONS

Table Three

Input/Output	Level/Load/Frequency	Detail
Input J1	Level	Up to 1.5 VRMs.
	Load	Greater than 100KΩ.
	Frequency	DC to 1.2 MHz.
Outputs J2, J3, and J4	Level	Dependent on input.
	Load	50Ω or greater.
	Frequency	Same as J1 Input.
Input J5	Level	Up to 1.5 VRMs.
	Load	Greater than 100KΩ.
	Frequency	DC to 1.2 MHz.
Outputs J6, J7, and J8	Level	Dependent on input.
	Load	50Ω or greater.
	Frequency	Same as J5 Input.
Input J9	Level	Up to 1.5 VRMs
	Load	Greater than 100KΩ
	Frequency	DC to 1.2 MHz
Outputs J10, J11, J12	Level	Dependent on Input
	Load	50Ω or greater
	Frequency	Same as J9 Input

Using Jumpers E1, E2, E3, and E4 allows the user to use one input and get multiple outputs. See Input/Output Table.

Input/Output Table

Input	Jumper	Outputs
J1	None	J2, J3, J4
J5	None	J6, J7, J8
J9	None	J10, J11, J12
J1 or J5	E1 to E2	J2, J3, J4, J6, J7, J8
J5 or J9	E3 to E4	J6, J7, J8, J10, J11, J12
J1, J5, or J9	E1 to E2, and E3 to E4	All Outputs

Input/Output Diagram

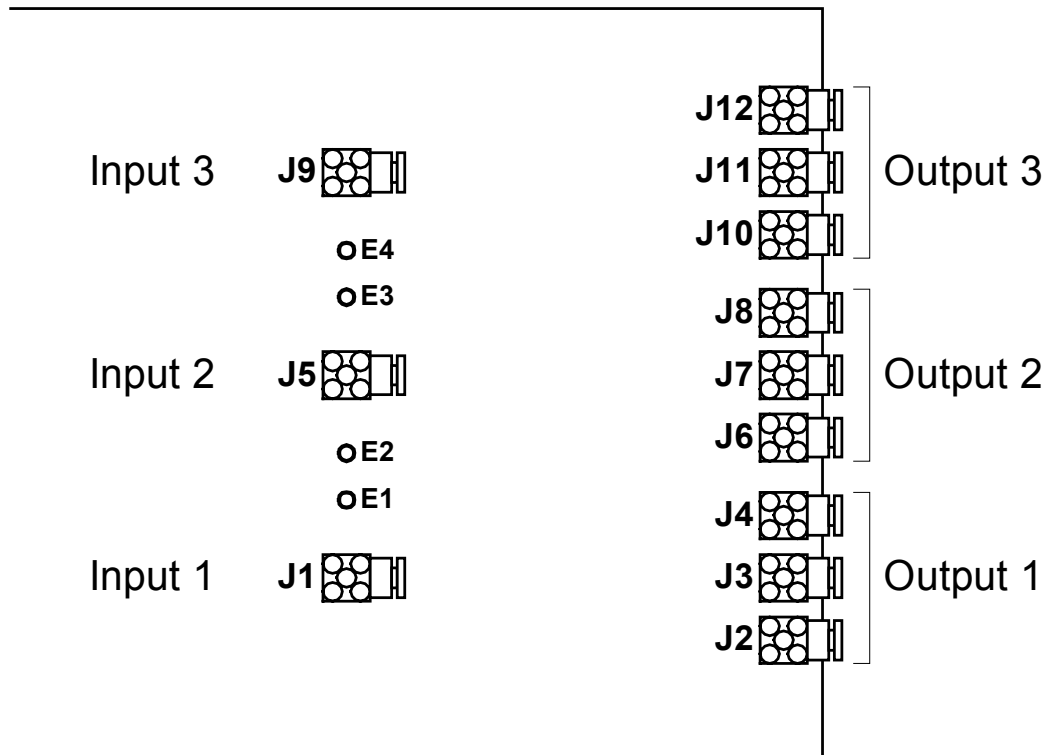

Part Number and Quantity Table

	Input	Output
Sealectro Corporation	051-428-3188-000	051-424-3188-0000
	Quantity Required	Quantity Required
	3	9

RECOMMENDED CABLES

Cable Usage Table

50Ω	RG-174/U, RG-188/U, RG-316/U
70Ω	RG-161/U
75Ω	RG-179/U, RG-187/U

RECOMMENDED CRIMPING TOOL

Sealectro Corporation

50-000-0090 or 50-000-0091

1.0 INTRODUCTION

This module provides a one input, three output buffer on a pulse rate generator assembly that can be installed into the TymMachine 7000.

Depending upon the dash number configuration, the three output buffers can output the buffered input signal or output pulse rates as follows:

Assembly Number	Description	TM Option
21057	50Ω output impedance via BNC connectors.	TM Option 45A
21057-1	Same as 21057 except 10kpps is generated instead of 20kpps.	TM Opt 45A
21057-2	Transformer coupled output via Twinax connectors.	TM Option 45B
21057-3	RS-422 outputs via Twinax connectors	TM Option 45C

1.1 GENERAL DESCRIPTION

This assembly can be built in three configurations and then jumpered to function as a buffer or pulse generator. Regardless of the configuration, to have this assembly function as a one input, three output buffer, install a jumper plug between JP1-2 and JP2-2 as shown in Figure One.

To configure this assembly as a pulse rate generator, jumper JP1-1 to JP2-1.

Figure One

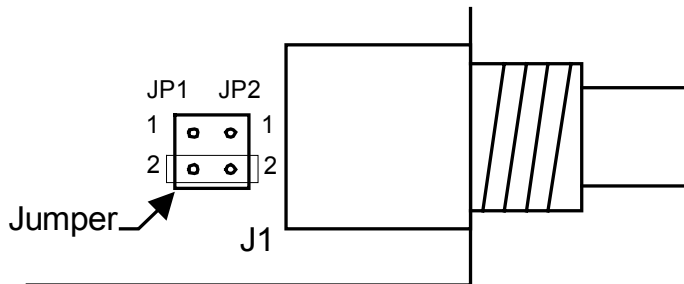

If this assembly is configured as a pulse rate generator, the pulses can be output as standard counter terms with duty cycles of 80% - 20% etc., or as pulse outputs with a pulse width of ten microseconds (rising edge on-time). To jumper as standard counter terms, install a jumper plug between JP3-2 and JP4-2 as shown in Figure Two.

Install the jumper plug between JP3-1 and JP4-1 for the ten microsecond pulse rate duration.

Figure Two

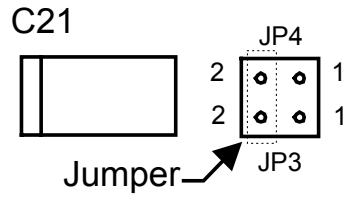

The following pulse rates can be selected using DIP switch SW1 as shown in Table One below:

Table One

SW1 Switch Position				Pulse Rate
1	2	3	4	
X	X	X	X	1mpps
	X	X	X	500kpps
X		X	X	100kpps
		X	X	50kpps
X	X		X	*20kpps
	X		X	5kpps
X			X	2kpps
			X	500pps
X	X	X		200pps
	X	X		100pps
X		X		50pps
		X		20pps
X	X			10pps
	X			5pps
X				1pps
				1ppm

* 10kpps is generated in lieu of 20kpps if 21057-1 Assembly is used.
 X = Closed (on).

1.2 CONFIGURATION/SPECIFICATIONS

ASSEMBLY 21057 (TM OPTION 45A)

One BNC input (J1) and Three BNC outputs (J2, J3, and J4).

- The output of this 1:1 buffer is dependent on the input.
- With a sinusoidal input of 1MHz to 10MHz, the outputs can be ... 1 VRMS (three volts peak-to-peak) terminated into 50Ω.
- With a TTL input (or pulse rates selected) the outputs will be TTL levels when terminated into 50Ω.

ASSEMBLY 21057-1 (TM OPTION 45A)

Same as Assembly 21057 except that 10kpps is generated instead of 20kpps.

ASSEMBLY 21057-2 (TM OPTION 45B)

One BNC input (J1) and Three Twinax outputs (J2, J3, and J4).

- With a one volt peak-to-peak sinusoidal input, the transformer coupled outputs have a flat frequency response from approx. 100Hz to 250Khz when terminated into a 75Ω resistive load.
- With a four volt peak-to-peak sinusoidal input, the transformer coupled outputs have a flat frequency response from approx. 350Hz to 230Khz when terminated into a 75Ω resistive load.
- This assembly is *not* intended to be used with pulse rates.
- The suggested mating connector for the Twinax connector is Amphenol part number 31-224 or equivalent.

ASSEMBLY 21057-3 (TM OPTION 45C)

One BNC input (J1) and Three Twinax outputs (J2, J3, and J4).

- With TTL level pulse rate inputs (or pulse rates selected to be generated), this assembly will output RS-422 differential outputs.
- This assembly is *not* intended to be used with sinusoidal inputs.

1.3 INSTALLATION

The card may be installed into any available option slot. The transformer coupled option (21057-2) must be installed in a bottom slot, because of the height of the transformers.

Table Two

Jumper Configuration		
	JP1/JP2	JP3/JP4
Buffer Assembly	JP1-2 to JP2-2	Not Used
Pulse Rate Assembly	JP1-1 to JP2-1	JP3-1 to JP4-1
Pulse Rate Assembly (10us Out)	JP1-1 to JP2-1	JP3-2 to JP4-2

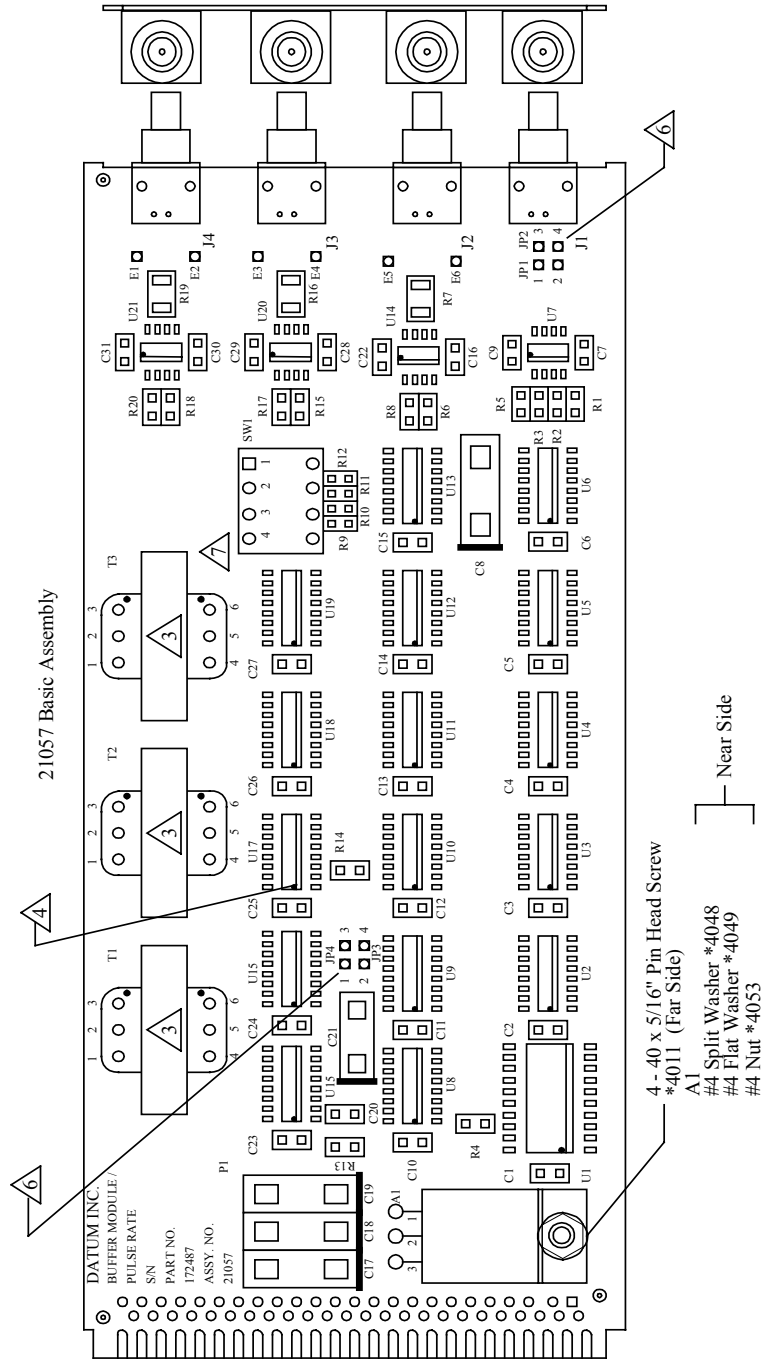



SYMMETRICOM TIMING & TEST
MEASUREMENT
3750 Westwind Blvd.
Santa Rosa, California 95403 USA
Tel: 707-528-1230
Fax: 707-527-6640
info@symmetricom.com
www.symmetricom.com

For more information about the complete range of Quality
Timing Products from the Symmetricom group of companies
call 1-800-544-0233 in the US and Canada.

Or visit our site on the world wide web at
<http://www.Symmetricom.com> for continuously updated
product specifications, news and information.